



UTIU
UNIVERSITÀ TELEMATICA
INTERNAZIONALE UNINETTUNO

Information and Communication Technologies Engineering

Automated Solar Street Light System

Bachelor Thesis
Uninettuno University - Helwan University

Authors:

Shereen Azzaz Akl
Yara Ashraf fathy
Reham Mohamed Reda
Omar Gamal Refaat
Muhammad Mustafa Zaki
Muhammad Mustafa Hijazi

Supervisors :

Dr. Dario Assante

Dr. Mustafa Abu Taleb

Certificate

This is to certify that this thesis reflects our original work towards the bachelor degree in information and Communication Technology from Uninettuno University in Egypt and Helwan University. The report embodies results of our original work, and studies are carried out by us and the contents of the report do not form the basis for the award of any other degree to the candidates from this Institution. Furthermore, all Due acknowledgments have been made to all other materials used to prevent credit-theft

ACKNOWLEDGEMENT

Firstly in this Acknowledgment, we thank almighty, our parents, brother, sisters and friends for their constant encouragement without which this project would not be possible.

We would like to express our gratitude to our supervisor prof. MustafaAbuTaleb for guidance and support throughout this project work. He has been a constant source of inspiration to us throughout the period of this work we have felt motivated and encouraged every time we attended his meeting. The success of any project depends largely on his encouragement & without this encouragement and guidance; this project would not have materialized. We would also like to thank him for showing us some example that related to the topic of our project .We consider ourselves extremely fortunate for having the opportunity to learn and work under his supervision over the entire period.

We also wish to thank DrAmr el Sayed, for his valuable guidance and advices. He was vital for the success of the project. We are grateful for your constant support and help.

We would also take this opportunity to express our gratitude and sincere thanks to Prof. Dario Assante for his valuable support.

Lastly, we would like to thank our administration, Dr. Mario Antonaci (Owner of Annoluce (CEO&Founder)) And Prof. Dario Assante for their efforts in coordinates our project and giving us all data required to finish our project.

ABSTRACT

Solar energy is rapidly gaining notoriety as an important means of expanding renewable energy resources. As such, it is vital that those in engineering fields understand the technologies associated with this area.

Its energy is both clean and free of cost. So maximizing the use of solar energy help to take the load off from fossil fuels like petrol, diesel, etc. and limit the emission of carbon dioxide hence preventing the pollution.

Our project will include the design and construction of an Arduino-based solar panel tracking system to control the auto intensity of the street lights systems. Solar tracking allows more energy to be produced because the solar array is able to remain aligned to the sun and therefore it will provide the maximum output power used in lightning the street lights at night. The project is also designed to detect vehicle movement on highwaysto switch ON only a block of street lights ahead of it (vehicle), And toswitch OFF the trailing lights to save energy. During night all the lights on the highway remain ON for the vehicles, but lots of energy is wasted when there is no vehicle movement. This proposed system provides a solution for energy saving. This is achieved by sensing an approaching vehicle and then switches ON a block of street lights ahead of the vehicle. As the vehicle passes by, the trailing lights switch OFF automatically. Thus, wesave a lot of energy. So when there are no vehicles on the highway, then all the lights remain OFF.

Table of Contents

Certificate	2
Acknowledgment	3
Abstract	4
Table of Contents	5
Chapter 1: Introduction	7
Overview.....	8
Solar Power in Egypt	12
Literal Review.....	19
Proposed Work	22
Chapter 2: Solar Engineering.....	28
Applications on Solar Technology	32
Concepts on Solar Radiation	35
Solar Tracker	39
Solar Panel	43
Solar Regulator	49
Chapter 3: Open Source Technologies	56
Open Source Microcontroller	58
Arduino Mega2560	63
Chapter 4: Mechanical System.....	75
Gear or Cogwheel	76
What is Teflon?	79

Why Artelon?	81
Chapter 5: Hardware Components	85
Photoresistor (LDR)	86
RTC	96
Detection Sensor	106
PIR Sensor.....	107
Adjustable Infrared Sensor.....	115
Display	121
Servo Motor	126
Chapter 6: Future Enhancement & UPS System	133
Lab View	135
UPS	138
Chapter 7: Implementation and budget	151
Steps of Implementation	152
Final Budget.....	155
Chapter 8: Conclusion and Result.....	157
Conclusion and Result.....	158
Appendices	
<hr/>	
Appendix A: Code of Implementation	160



Chapter 1:

Introduction

OVERVIEW

The world population is increasing day by day and the demand for energy is increasing accordingly. Oil and coal as the main source of energy nowadays, is expected to end up from the world during the recent century which explores a serious problem in providing the humanity with an affordable and reliable source of energy. The need of the hour is renewable energy resources with cheap running costs. Solar energy is considered as one of the main energy resources in warm countries.

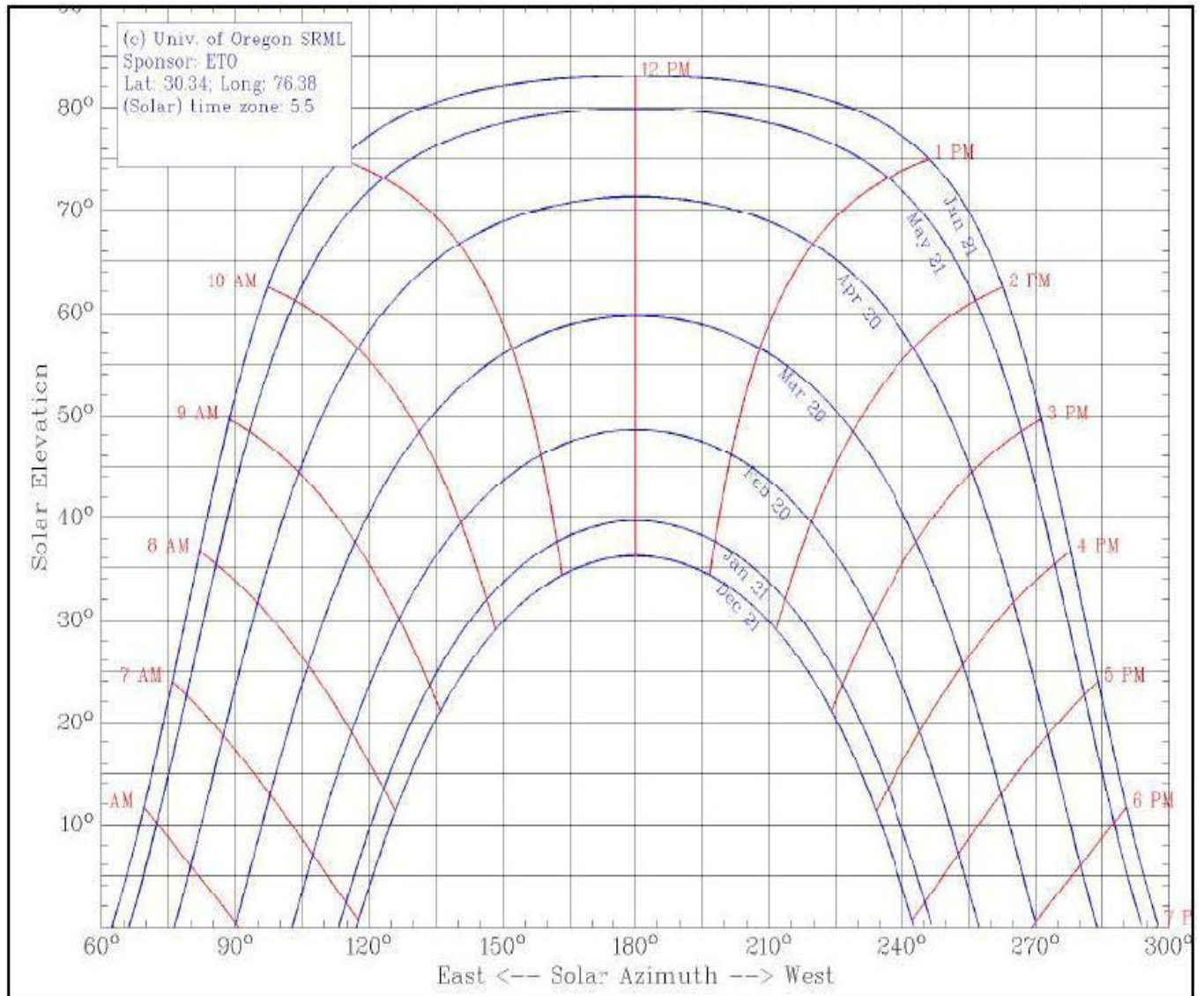

Solar energy is very large inexhaustible source of energy. The power from the sun hindered by the earth is approximately 1.8×10^{11} MW, which is manifold thousands of times larger than the present consumption rate on the earth of all commercial energy sources. Thus solar energy could supply all present and future needs of the world on a continuous basis such can be the most promising unconventional energy sources. In addition to its size, solar energy has two other factors in its favor, first unlike fossil fuel and

nuclear power, it is a clean source of energy. Second it is free and available in adequate quantities in almost all parts of the world where people live. The sun as we know is the back bone of living kingdom, it's all because of which there is life on the earth. The solar radiation matters most on the life of the animals and human.

In general, Egypt has a relatively long sunny day for more than ten months and partly cloudy sky for most of the days of the rest two months. This makes our country, especially the deserts such as Blue Desert, Eastern Desert, Egyptian Sand Sea, Libyan Desert, Qattara Depression, and Sinai Desert which are very rich in solar energy. Many projects have been done on using photovoltaic cells in collecting solar radiation and converting it into electrical energy but most of these projects did not take into account the difference of the sun angle of incidence by installing the panels in a fixed orientation which influences very highly the solar energy collected by the panel.

As we know that the angle of inclination ranges between -90 degree after sun rise and $+90$ degree before sun set passing with 0 degree at noon. This makes the collected solar radiation to be 0% at sun rise and sun set and 100% at noon. This variation of solar radiations collection leads the photovoltaic panel to lose more than 40% of the collected energy.

The Fig. shows the yearly sun path at the latitude of 30 degree

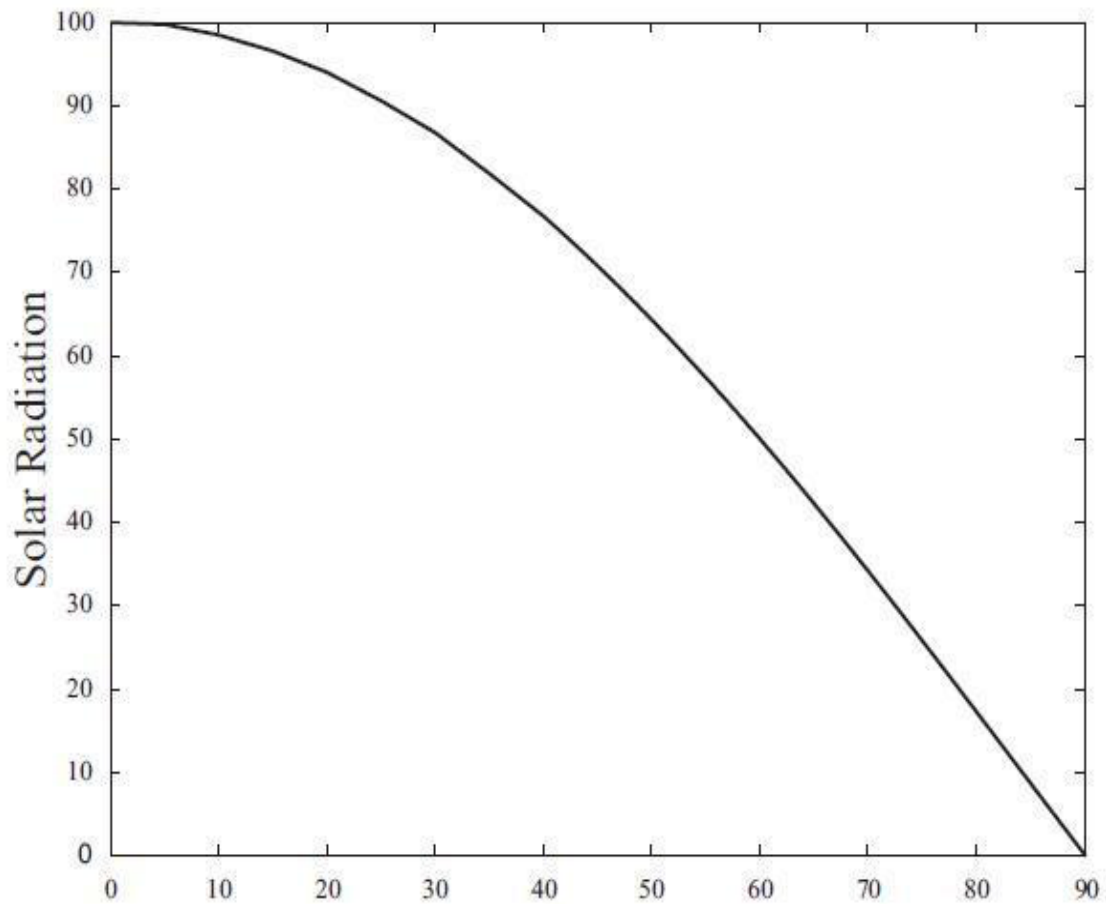

Fig. Curve for the relationship between the solar radiation and the solar angle of incidence.

From the figure, one can estimate the exact position of sun in every Month and at any time during the day. The position is decided by two angles in spherical coordinates; the Altitude angle which is the angle of the sun in the vertical plane in which the sun lies, and the Azimuth angle which represents the angle of the projected position of the sun in the horizontal plane. These two angles will be discussed deeply later in this document. Fig. 1.2 shows a curve for the relationship between the solar radiation and the solar angle of incidence. This figure shows that solar radiations falling on the solar array will be maximum when the angle of incidence on the panel is 0° which means that the panel is perpendicular to the sun.

Solar Power In Egypt

Egypt belongs to the global sun-belt. The country is in advantageous position with solar energy. In 1991 solar atlas for Egypt was issued indicating that the country enjoys 2900-3200 hours of sunshine annually with annual direct normal energy density 1970-3200 kWh/m² and technical solar-thermal electricity generating potential of 73.6 Petawatthour (PWh). Egypt was among the first countries to utilize solar energy. In 1910, a practical industrial scale solar system engine was built at Maadi south to Cairo using solar thermal parabolic collectors. The engine was used to produce steam which drove a series of large water pumps for irrigation. Nowadays utilization of solar energy includes use of photovoltaic cells, solar water heating and solar thermal power. Use of solar thermal technology may include both electricity generation and water desalination, which is advantageous for Egypt taking in consideration its shortage in

water supply. The article discusses perspectives of solar energy in Egypt and developmental trends till 2050.

Egypt's Needs for Energy

Energy is a major drive of modern economic development. With the increase of world population, more energy is required to satisfy rising human needs to maintain welfare. Improving of living standards and prolongation of human life itself depends, in the average, on the energy consumption per person. Moreover global demand for energy grows as more developing countries enter industrial and service stages of their development. In Egypt, as everywhere, energy plays a substantial role in country's economic development contributing to macroeconomic variables as gross domestic product (GDP), commodity exports and investments. On the other hand, Egypt as a developing fast growing country suffers from rapid annual population growth currently at a rate of 1.68%. As of July 2008, the population of Egypt was estimated as 78.9 millions. According to the Cairo Demographic Centre, Egypt's population is expected to reach 110 million by 2031 and 128 million by 2051. Such a fast population growth along with other environmental challenges is overstraining the limited energy resources of the country .Fig.1.2 shows Egypt's projected population growth till 2036.

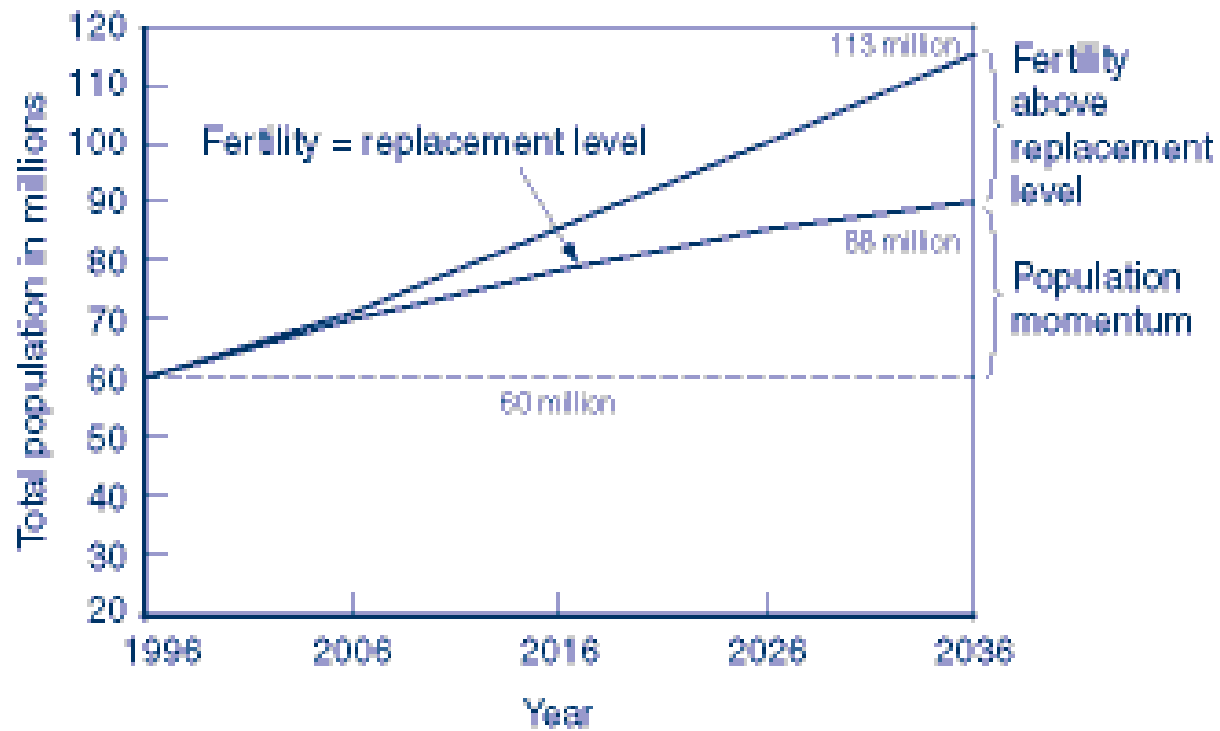

Fig 1.2. Egypt's projected population growth till 2036

On the other hand improvement of human factor indicators including health care and general welfare necessitates corresponding increase in per capita electric power consumption, as indicated in table 1. A carefully tailored energy policy is to be implemented to attain sustainable development.

Table 1. Egypt's population and electric power indicators (2007-2052)

Year	2007	2012	2017	2022	2027
Population (million)	78.3	85.2	92.1	98.8	105.1
Per capita installed power (MW/c)	0.28	0.34	0.41	0.48	0.55
Total (GW)	21.9	29.0	37.8	47.1	57.7
Installed power annual growth rate (%)	4.4	5.8	5.4	4.5	4.0
Year	2032	2037	2042	2047	2052
Population (million)	111.1	116.5	121.2	125.3	128.5
Per capita installed power (MW/c)	0.63	0.72	0.82	0.92	1.02
Total (GW)	70.0	84.0	100	115	132
Installed power annual growth rate (%)	4.0	3.7	3.5	2.8	2.7

EGYPT ENERGY PROFILE

Primary sources of energy in Egypt include:

- Crude oil and natural gas
- Hydropower
- New and renewable energy: mostly wind and solar
- Other minor sources in rural areas as agricultural and animal residues
- The state had adopted plans to establish electronuclear stations that produceElectricity through nuclear means.

Status of Egypt's oil and gas balance during the period 1997-2007 is summarized in table 2.

Table 2. Egypt's oil/gas balance

	1997	1999	2001	2003	2005	2007
Oil						
Production (10 ³ barrels/d)	856	852	720	712	658	637
Consumption (10 ³ barrels/d)	531	563	544	561	604	680
Proved reserves (Billion barrels)	3.70	3.50	2.95	3.70	3.70	3.70
Natural Gas						
Production (B cubic feet)	477	518	867	1058	1501	7.5/d
Consumption (B cubic feet)	477	518	867	1046	1208	6.1/d
Proved reserves (T cubic feet)	20.36	31.50	35.18	58.5	58.5	66.0

Egypt is in advantageous position with solar energy. It belongs to the global Sun Belt, Fig. 2. In 1991 solar atlas for Egypt was issued indicating that the country enjoys 2900-3200 hours of sunshine annually with annual direct normal energy density 1970-3200 kWh/m² and technical solar-thermal electricity generating potential of 73.6 Petawatt.hour (PWh) . Egypt was among the first countries to utilize solar energy. In 1910, American engineer F. Shuman built a practical industrial scale solar system engine at Maadi south to Cairo using solar thermal parabolic collectors, Fig. 3. The engine was used to produce steam which drove a series of large water pumps for Irrigation.

Due to Egypt's location, topography and climate, Egypt has an average level of solar radiation of between 2,000 to 3,200 kWh per square meter a year, giving it significant potential for utilizing this form of renewable energy. To date, however, uptake of solar projects has been slow due to

high capital costs. In 2010, Egypt's only major solar power project was commissioned in Kuraymat. The plant is a 140MW solar thermal combined cycle power plant of which 20MW is from solar energy.

Egypt is recognized as having vast potential for solar energy application, but the investment cost of solar power plants is currently very high in comparison with oil and gas fired power plants and it is envisaged that Egypt's strategy for developing its renewable energy capacity will be mainly directed at the wind sector.

Proceedings of the 4th Environmental Physics Conference, 10-14 March 2010, Hurghada, Egypt

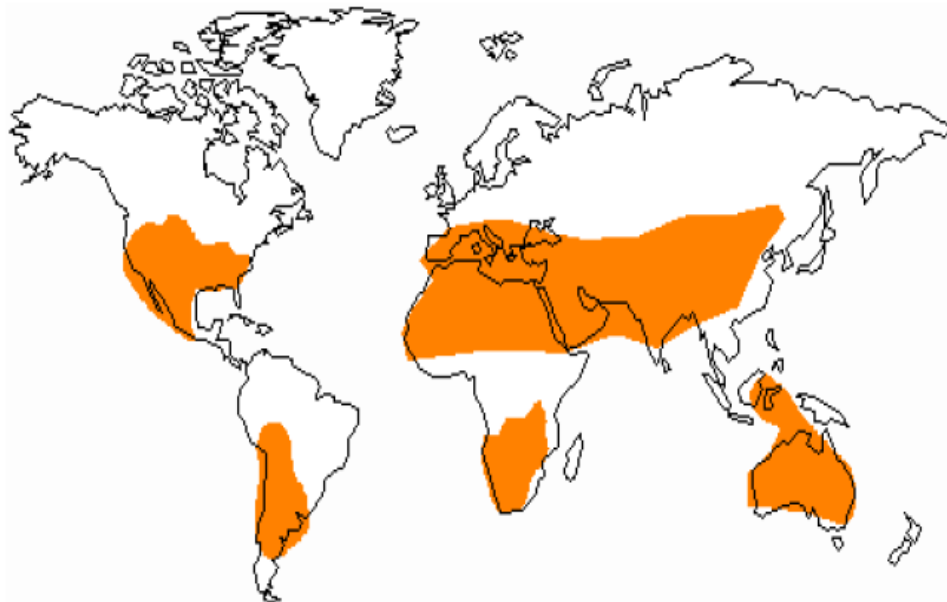

Fig. 2. Egypt as part of the solar belt.

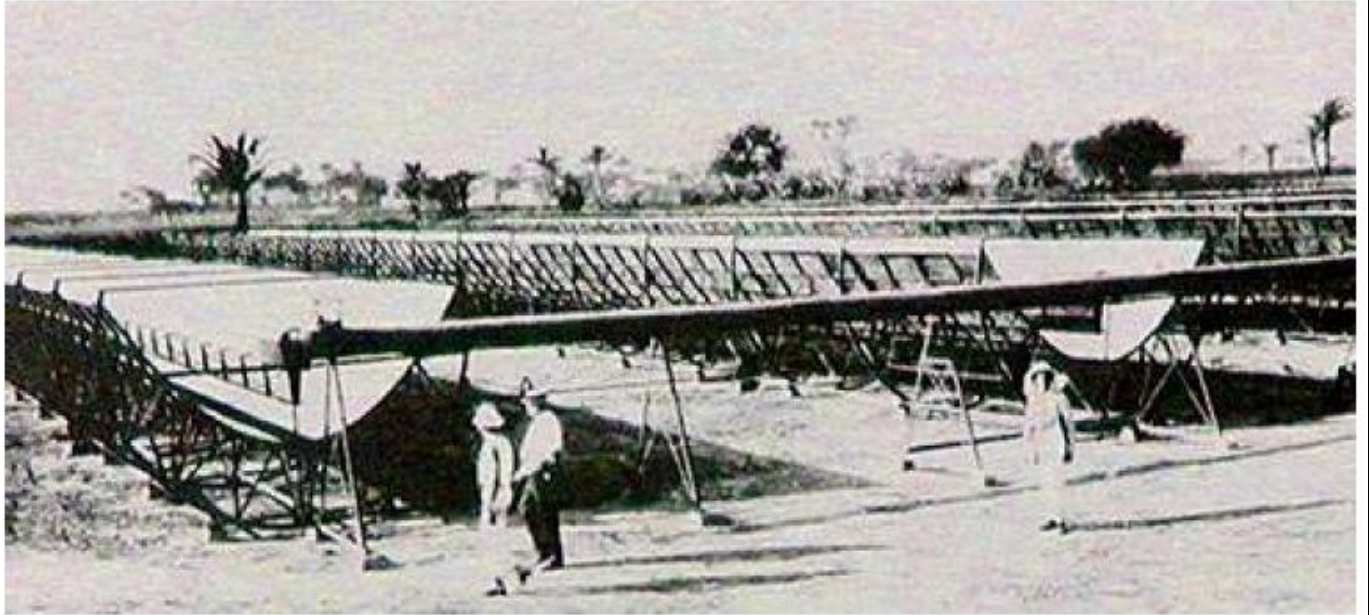

Fig. 3 Frank Shuman parabolic solar collectors, Maadi 1912.

Distribution of solar direct normal irradiance over Egypt is shown in Fig. 4. As is clear from Fig. 5 preferable locations for solar energy farms are along the North Coast, while those for wind energy farms are along the Red Sea Coast and in the West of Oweinat area.

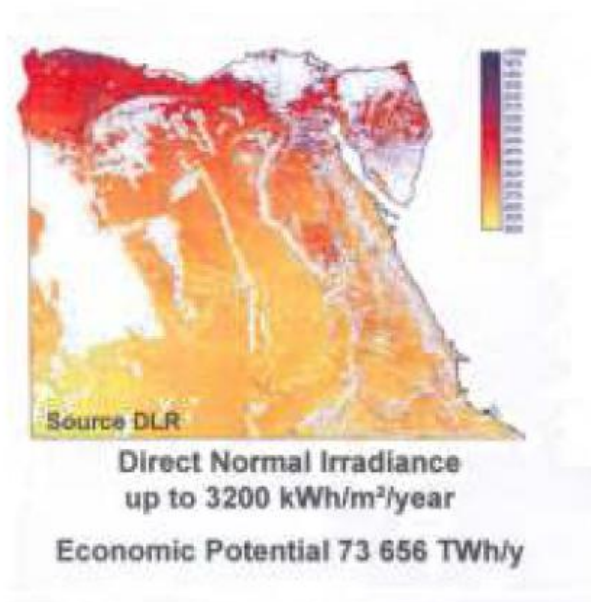

Fig. 4. Distribution of solar direct normal

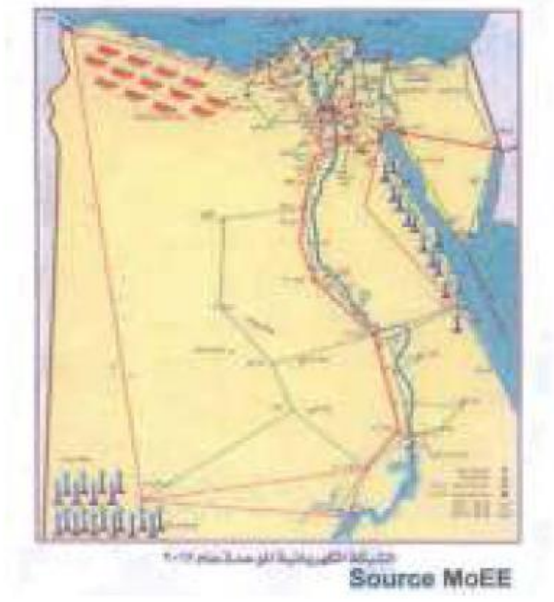

Fig. 5. Preferred locations for renewable

LITERATURE REVIEW

Sun-synchronous navigation is related to moving the solar powered panel in such a way that its solar panel always points toward the sun and which results into maximum battery charging that will be used in lighting the street lights . The unique feature of this solar tracking system is that instead of taking the earth as its reference, it takes the sun as a guiding source. Its active sensors constantly monitor the sunlight and rotate the panel towards the direction where the intensity of sunlight is maximum. The light dependent resistor's do the job of sensing the change in the

position of the Sun. The control circuit does the job of fetching the input from the sensor and gives command to the motor to run in order to tackle the change in the position of the sun. By using this system the additional energy generated is around 25% to 30% with very less consumption by the system itself.

The documentation gives the design and implementation of an arduinobased auto intensity control of the street lights system using an arduino based sun tracking system to enhance the power output of photovoltaic solar panels. The tracking system was driven by two servo dc motors to provide motion of the PV panel in two axes. The project describes the use of an arduino based design methodology of an automatic solar tracker. Light dependent resistors are used as the sensors of the solar tracker. The tracking system maximizes solar cell output by positioning a solar panel at the point of maximum light intensity. This paper describes the use of DC motors, special motors like servo motors. The system was designed as the normal line of solar cell always move parallel to the rays of the sun.

The main function of all tracking systems is to provide one or two degrees of freedom in movement. Trackers are used to keep solar collectors/solar panels oriented directly towards the sun as it moves through the sky every day

There are two types of sun trackers single-axis and dual-axis.

Single axis tracker:

It moves back and forth in east-west direction. Because of axial tilt of the Earth, the inclination of Sun's trajectory in the sky varies over the course of the year. Single axis tracker cannot follow Sun's trajectory.

Dual axis tracker:

It can track sun in continuous manner as it can move in two different west and north-south) directions i.e. it follows Sun's exact trajectory.

Using solar trackers increases the amount of solar energy which is received by the solar energy collector and improves the energy output of the heat/electricity which is generated. Solar trackers can increase the output of solar panels by 20-30% which improves the economics of the solar panel project.

The Aim of this project is to develop and implement a prototype of two-axis solar tracking system based on an arduino.

Objective

Our objective is to create a Solar Tracker Device that follows the movement of the sun as it rotates from the east to the west every day. It aligns solar panel or module towards the sun. This device follows the sun's path throughout the day by changing their orientation. Tracking maximizes energy capture. Amount of energy captured depends upon angle of incidence (angle made by rays to the line perpendicular to the surface) between incoming light rays and module. When angle of incidence is minimum, captured power is maximum. Concentrated solar systems have optics that directly accepts sun rays, so solar tracker must be aligned correctly. All concentrated solar systems have trackers as these systems are unable to produce energy unless directs rays fall on them.

The main function of all tracking systems is to provide one or two degrees of freedom in movement. Trackers are used to keep solar collectors/solar panels oriented directly towards the sun as it moves through the sky every day in order to control the Auto intensity of a street lights system; where there is no need of high intensity in peak hours i.e. when there is no traffic and even in early mornings. So we are aiming to reduce the intensity in these times, energy can be saved to some extent.

Proposed work

Digital Systems Component: Breadboard

The Arduino microcontroller, photoresistors, servo motors and LCD display will all be connected to the breadboard as shown on Figure

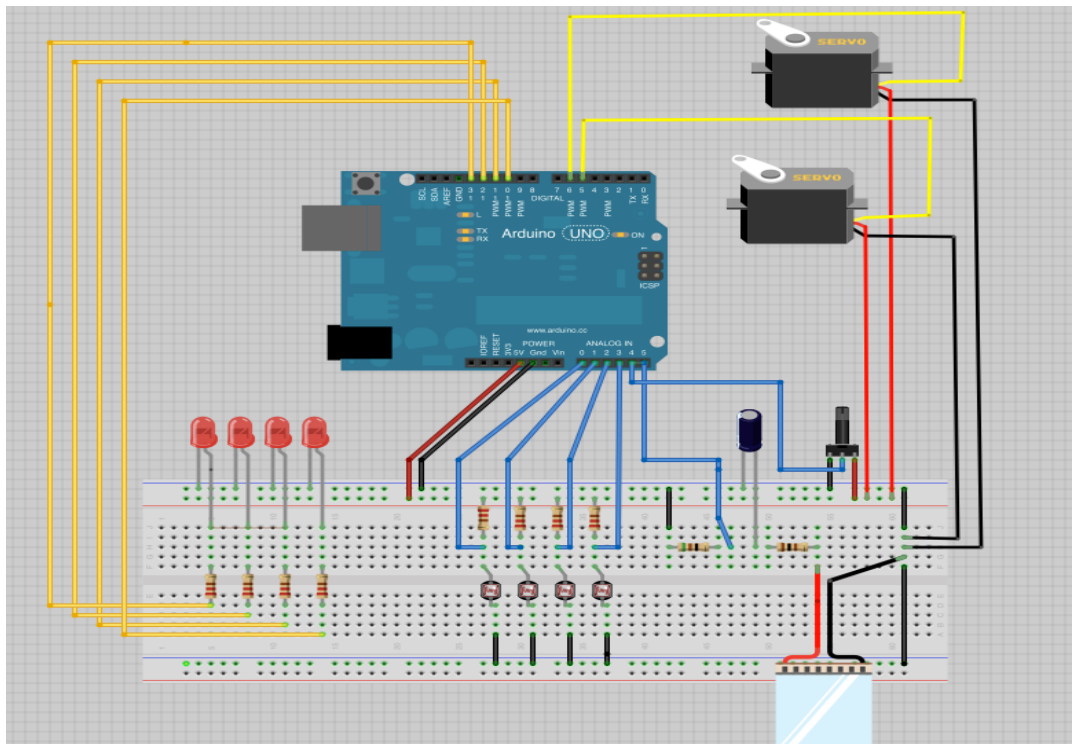

Figure: Breadboard Layout

Power will be calculated by measuring current and voltage across the photoresistors. The resistance of a photoresistor decreases with light intensity. This enables the device to determine where to move based on which photoresistor detects the most light. Data from the photoresistors will be processed on the Arduino microcontroller, which uses an algorithm to determine the direction of the brightest light source. The microcontroller will then signal the servo motors to move and display the angle values on the LCD screen.

Control Systems Component

Figure outlines the negative feedback block diagram of the system.

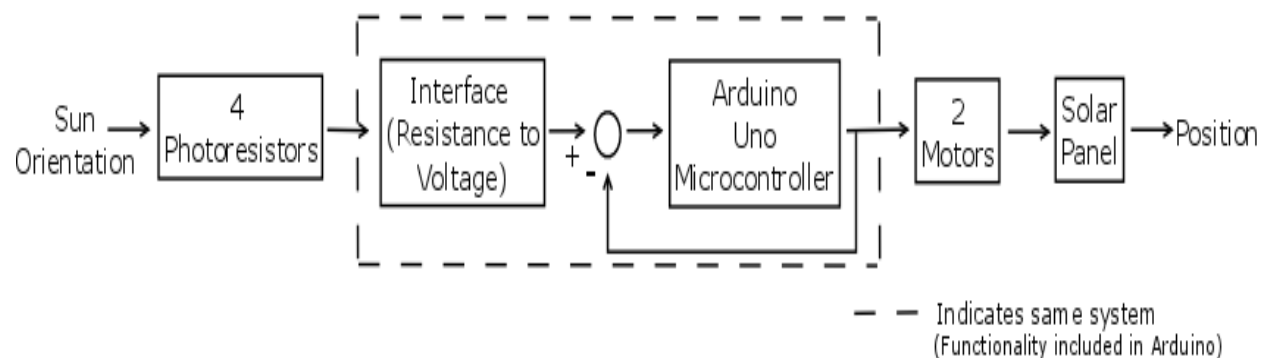

Figure: Negative Feedback Diagram

The input of this negative feedback system is the sun orientation. The sun orientation is detected by four photoresistors, which produce different resistive intensities based on the intensity of the photos received. The resistive intensity is converted to voltage in the Arduino microcontroller, which sends analog signals to the two servo motors. These motors control the orientation of the solar panel. Unity feedback occurs at the analog output of the microcontroller. The Arduino will continue to monitor the four photoresistors and signal the motors to move the solar panel until all

the photoresistors receive the same light intensity. By this point, the solar panel will be in the optimal orientation for maximum power production.

Mechanical Component:

The sun tracking solar project contains many mechanical components. These components include the frame and the motors.

Frame

The frame, which is shown on Figure, can be divided into two components. The first component consists of the frame that holds the solar panel and contains the two servo motors which move horizontal & the vertical which moves the panel. The panel rotates the panel in the y-axis direction.

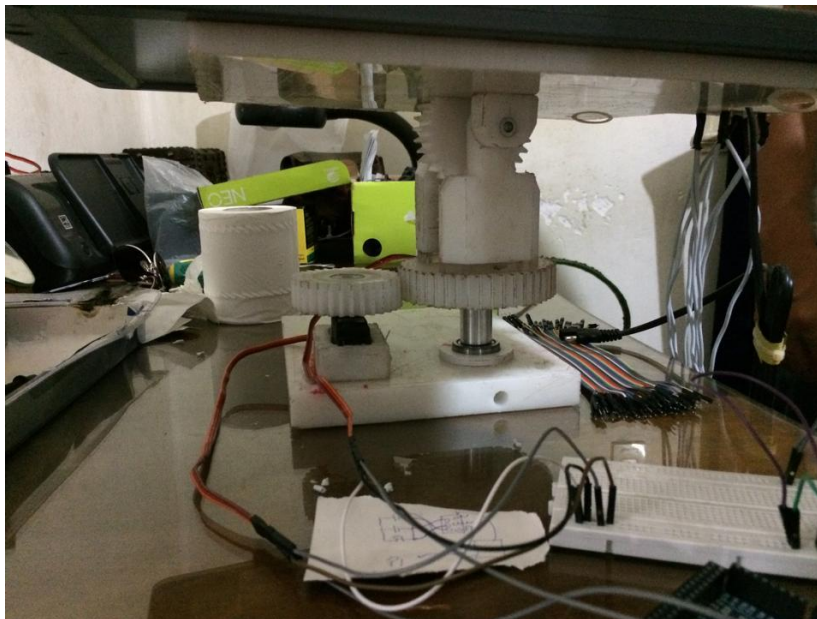

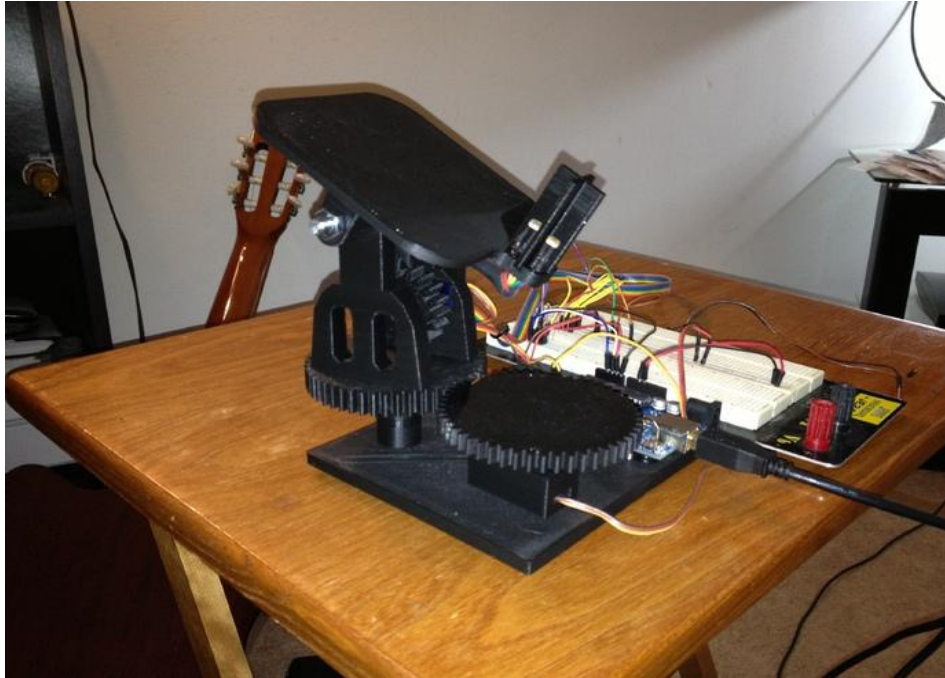

The second frame component is the base for the photoresistors. The key is to place the photoresistors on the base so each is oriented in a different direction. Photoresistor placement is crucial because the photoresistors will determine which direction the solar panel should move in order to receive the greatest light intensity for maximum power production. Figures 10 and 11 display the two possible configurations that will be tested.

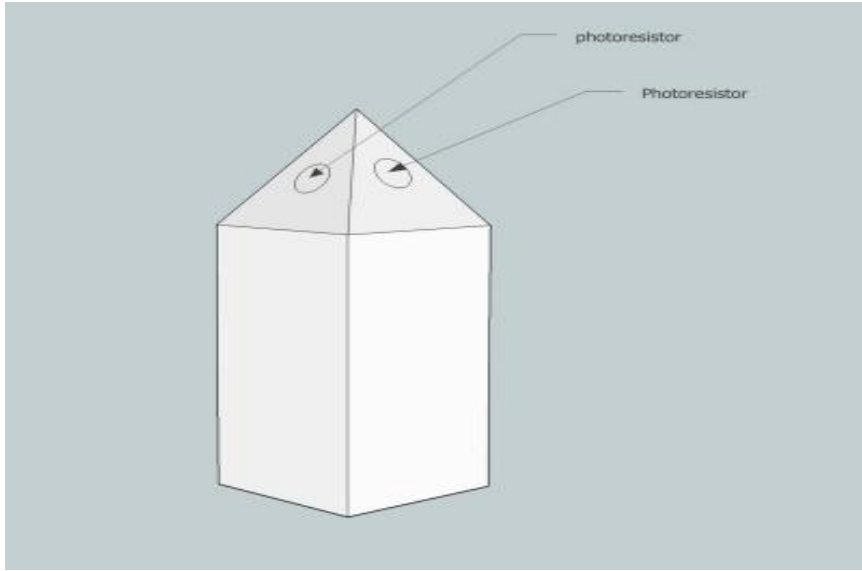

Figure: Cone Configuration for Photoresistor Frame

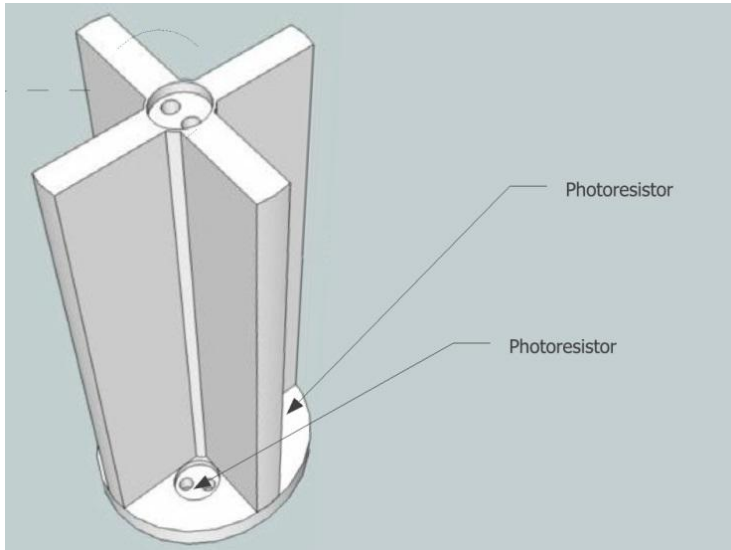

Figure: Cross Configuration for Photoresistor Frame

The cone design allows each of the four photo resistors to be angled in opposite directions. The angle allows for accurate detection of the position of the light source. The cross design allows for a sun-dial effect for the four photoresistors. The photoresistor within the direction of the light source receives the most amount of light while the others are shadowed out. In both designs, the panel will move toward the direction of the photoresistor with the lowest resistance (facing the greatest light intensity) and will continue to move until resistance in each photoresistor is approximately the same. Equal resistance levels indicate that the solar panel is directly oriented in the position of the light source.



Chapter 2:
Solar
Engineering

Introduction to Solar Engineering in Egypt

Egyptian electricity consumption statistics show that Cairo is among the world's most lively and brightly lit cities, with extremely high levels of energy consumed for lighting up households and streets. The required levels of energy often exceed the capacity of what can be delivered. This causes the government and officials to be stuck between two choices: more energy production or less consumption.



Egypt receives annually 2,400 hrs of solar operation with high intensity of solar radiation equivalent to 2,600 KWh/m².

On average, the Egyptian house requires five kilowatt hours of electricity/day, meaning that it uses up to 1,500 kilowatt hours per month. The problem is that the majority of Egyptians lack awareness when it comes to the consumption and preservation of energy.

Contrary to popular belief, preservation of energy is a very easy process that can achieve savings up to 15% of this precious divine gift in order to startup our lives. Additionally, there are numerous alternatives that can make generating energy less costly.

Thousands of years ago, the ancestors of modern Egyptians worshipped the Sun, and believed it was a god named Ra. This concept didn't pop up in the minds of ancient Egyptians haphazardly. On the contrary, those scientifically-minded Egyptians were totally aware of the importance of the Sun from both a philosophical and scientific points of views. They understood the roles played by the Sun in raising their crops and plants, evaporating the water of the Nile, warming their environment and surroundings, and sterilizing by the heat of the Sun.

Nowadays, centuries later, Egypt is just starting to recognize how essential and influential the Sun can be as a clean and an ever-lasting energy source. Being among the most sunlight-sufficient places on the globe with an estimated annual 2,400 hours of solar operation, compared with maximum European figures of 1,900 in Spain and Greece, the next-closest countries, it's only appropriate that Egyptians start experiencing with whatever possibilities solar energy has to offer as it reaches their lands by a high intensity of direct solar radiation equivalent to 2,000-2,600 KWh/m².

In the aftermath of January 25th uprising, and due to constant power cuts around Egypt, the demand and need for more clean energy sources has been on the rise.

Solar energy

It is a radiant light and heat from the sun harnessed using a range of ever-evolving technologies such as solar heating, solar photovoltaics, solar thermal electricity, solar architecture and artificial photosynthesis.

Solar technologies are broadly characterized as either passive solar or active solar depending on the way they capture, convert and distribute solar energy. Active solar techniques include the use of photovoltaic panels and solar thermal collectors to harness the energy. Passive solar techniques include orienting a building to the Sun, selecting materials with favorable thermal or light dispersing properties, and designing spaces that naturally circulate air.

In 2011, the International Energy Agency said that "the development of affordable, inexhaustible and clean solar energy technologies will have huge longer-term benefits. It will increase countries' energy security through reliance on an indigenous, inexhaustible and mostly import-independent resource, enhance sustainability, reduce pollution, lower the costs of mitigating climate change, and keep fossil fuel prices lower than otherwise. These advantages are global. Hence the additional costs of the incentives for early deployment should be considered learning investments; they must be wisely spent and need to be widely shared".

Solar Technology

Solar energy is the cleanest, most abundant renewable energy source available, and the U.S. has some of the world's richest solar resources. Today, people and businesses across America are harnessing the light and heat of the sun to save money, create jobs, and power our country with clean, sustainable energy.

Solar technologies can be used at or near the point where the energy is needed, referred to as distributed generation (DG). Distributed solar energy is typically located on rooftops or ground-mounted arrays close to where the energy is used. Some solar technologies can also be built at utility-scale, to produce large amounts of energy for transmission and distribution over wide geographic areas.

Applications of solar technology

Solar energy refers primarily to the use of solar radiation for practical ends. However, all renewable energies, other than geothermal and tidal, derive their energy from the sun.

Solar technologies are broadly characterized as either passive or active depending on the way they capture, convert and distribute sunlight. Active solar techniques use photovoltaic panels, pumps, and fans to convert sunlight into useful outputs. Passive solar techniques include selecting materials with favorable thermal properties, designing spaces that naturally circulate air, and referencing the position of a building to the Sun. Active solar technologies increase the supply of energy and are considered supply side technologies, while passive solar technologies reduce the need for alternate resources and are generally considered demand side technologies.

- Architecture and urban planning

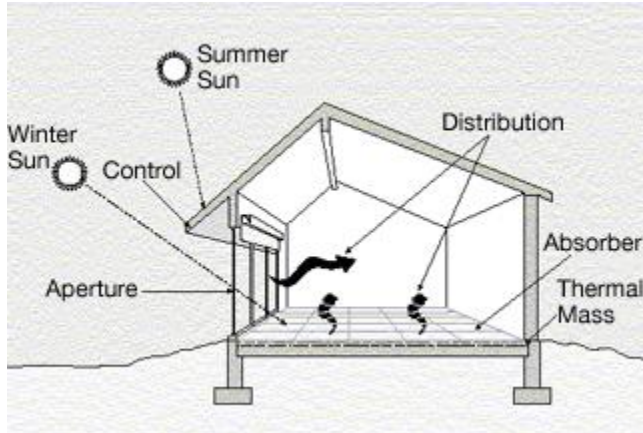

- Agriculture and horticulture



- Transport and reconnaissance



- Heating, cooling and ventilation



Electricity production



CONCEPTS ON SOLAR RADIATION

Before talking about the solar tracking systems, we will review some basic concepts concerning solar radiation and mention some important values to better understand the results of this work.

The sun, at an estimated temperature of 5800 K, emits high amounts of energy in the form of radiation, which reaches the planets of the solar system. Sunlight has two components, the direct beam and diffuse beam. Direct radiation (also called beam radiation) is the solar radiation of the sun

that has not been scattered (causes shadow). Direct beam carries about 90% of the solar energy, and the "diffuse sunlight" that carries the remainder. The diffuse portion is the blue sky on a clear day and increases as a proportion on cloudy days. The diffuse radiation is the sun radiation that has been scattered (complete radiation on cloudy days). Reflected radiation is the incident radiation (beam and diffuse) that has been reflected by the earth. The sum of beams, diffuse and reflected radiation is considered as the global radiation on a surface. As the majority of the energy is in the direct beam, maximizing collection requires the sun to be visible to the panels as long as possible.

Insulation

Insulation is a measure of solar radiation energy received on a given surface area and recorded during a given time. It is also called solar irradiation and expressed as hourly irradiation if recorded during an hour, daily irradiation if recorded during a day, for example. The unit recommended by the World Meteorological Organization is MJ/m² (mega joules per square meter) or J/cm²

(Joules per square centimeter). Practitioners in the business of solar energy may use the unit Wh/m² (watt-hours per square meter). If this energy is divided by the recording time in hours, it is then a density of power called irradiance, expressed in W/m² (watts per square meter). Over the course of a year the average solar radiation arriving at the top of the Earth's atmosphere at any point in time is roughly 1366 watts per square meter. The Sun's rays are attenuated as they pass through the atmosphere, thus reducing the irradiance at the Earth's surface to approximately 1000 W m⁻² for a surface perpendicular to the Sun's rays at sea level on a clear day. The insulation of the sun can also be expressed in Suns, where one Sun equals 1000 W/m²

Projection Effect:

The insulation into a surface is largest when the surface directly faces the Sun. As the angle increases between the direction at a right angle to the surface and the direction of the rays of sunlight, the insulation is reduced in proportion to cosine of the angle; see effect of sun angle on climate.

This 'projection effect' is the main reason why the Polar Regions are much colder than equatorial regions on Earth. On an annual average the poles receive less insulation than does the equator, because at the poles the Earth's surface are angled away from the Sun.¹⁹

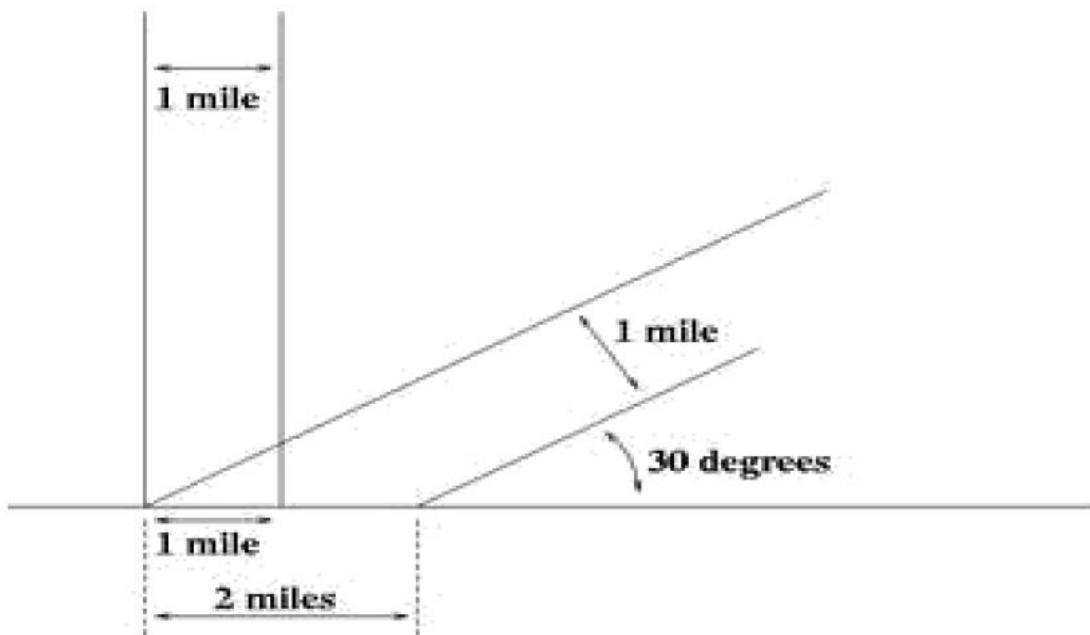

One beam one mile wide shines on the ground at a 90° angle, and another at a 30° angle. The one at a shallower angle distributes the same amount of light energy over twice as much area.

WORKING OF PHOTOVOLTAICS:

Photovoltaic are the direct conversion of light into electricity at the atomic level. Some materials exhibit a property known as the photoelectric effect that causes them to absorb photons of light and release electrons. When these free electrons are captured, electric current results can be used as electricity.

A solar cell (also called photovoltaic cell or photoelectric cell) is a solid state electrical device that converts the energy of light directly into electricity by the photovoltaic effect. Crystalline silicon PV cells are the most common photovoltaic cells in use today.

A number of solar cells electrically connected to each other and mounted in a support structure or frame are called a photovoltaic module. Modules are designed to supply electricity at a certain voltage, such as a common 12 volts system. The current produced is directly dependent on how much light strikes the 20 Module. Multiple modules can be wired together to form an array. In general, the larger the area of a module or array, the more electricity will be produced. Photovoltaic modules and arrays produce direct-current (DC) electricity. They can be connected in both series and parallel electrical arrangements to produce any required voltage and current combination.

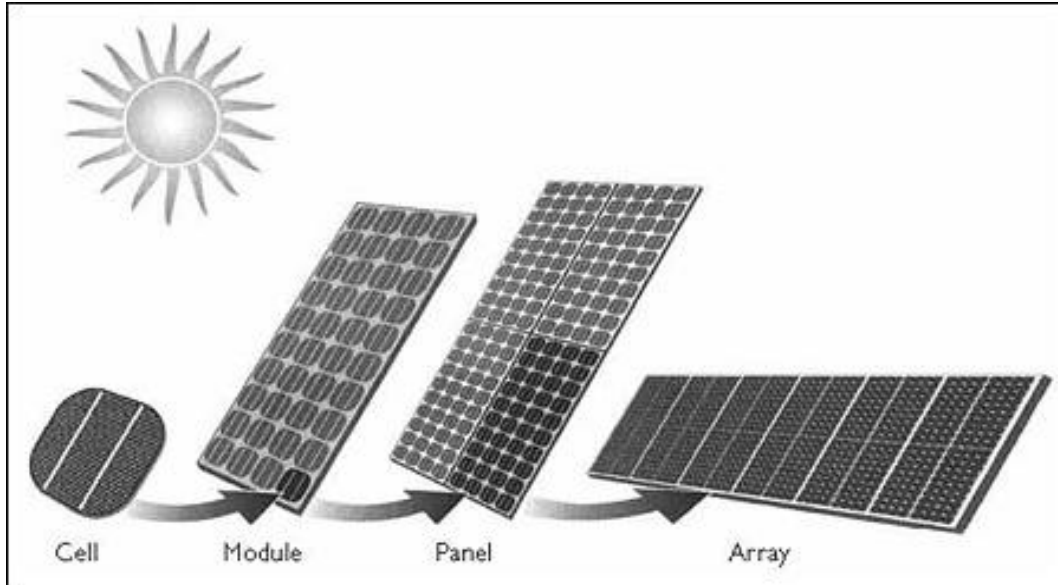

Photovoltaic panel or array

Solar Tracker

It is a Device which follows the movement of the sun as it rotates from the east to the west every day. The main function of all tracking systems is to provide one or two degrees of freedom in movement. Trackers are used to keep solar collectors/solar panels oriented directly towards the sun as it moves through the sky every day. Using solar trackers increases the amount of solar energy which is received by the solar energy collector and improves the energy output of the heat/electricity which is generated. Solar trackers can increase the output of solar panels by 20-30% which improves the economics of the solar panel project.

TYPES OF SOLAR TRACKERS:

- **PASSIVE TRACKING SYSTEMS**

The passive tracking system realizes the movement of the system by utilizing a low boiling point liquid. This liquid is vaporized by the added heat of the sun and the center of mass is shifted leading to that the system finds the new equilibrium position.

- **ACTIVE TRACKING SYSTEMS**

The two basic types of active solar tracker are single-axis and double-axis.

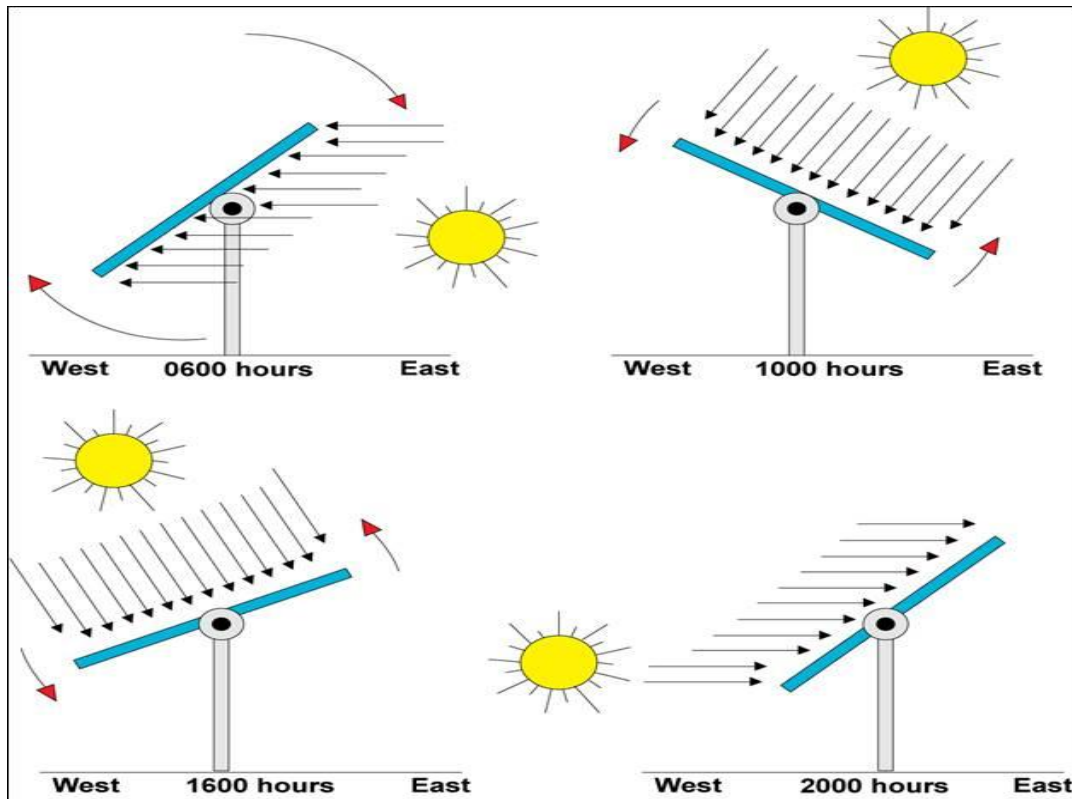

- Dual Axis Trackers

Dual axis trackers as shown in the have two degrees of freedom that act as axes of rotation. Double-axis solar trackers, as the same suggest, can rotate simultaneously in horizontal and vertical directions, and so are able to point exactly at the sun at all times in any location.

Dual axis tracking systems realize movement both along the elevation- and azimuthally axes. These tracking systems naturally provide the best performance, given that the components have high enough accuracy as well.



The received solar radiation actually depends on the given location on the earth such as, on its geographical position, the date of the year and on the time of the day. That is because of the rotation of the earth around the sun in a year and its rotation around itself in a day (Lenoble, 1993).

The solar radiation going through the atmosphere is partially absorbed by its constituents, partially reflected back to space and partially diffused, with the remaining reaching the ground as a direct solar radiation. In a planetary scale 17% of solar radiation is absorbed by the atmosphere, 30% is reflected by the constituents of the atmosphere, and 53% reaches the surface of the earth, 31% of it as direct radiation and 22% as diffuse solar radiation (Sellers, 1965).

NREL's Measurement & Instrumentation Data Center provides web based applications for calculating solar and lunar position and/or solar intensity. NREL's MIDC SOLPOS Calculator calculates the location of the Sun in the sky and its intensity for any given location, day, and time, and it is valid from the year 1950 to 2050 with an uncertainty of +/- 0.01 degrees. The rate at which solar energy reaches a unit area at the earth is called the "solar irradiance" or "insolation". The units of measure for irradiance are watts per

square meter (W/m²). Solar irradiance is the power of electromagnetic radiation per unit area incident on a surface.

According to sunrise and sunset times written for 2014 in the following site, <http://www.timeanddate.com/sun/egypt/cairo?month=8&year=2014>

Latest sunrise occurs at approximately 07 & the earliest sunset at approximately 16 and so night will definitely be between 4 pm and 7 am.

Solar panel

A solar panel is a set of solar photovoltaic modules electrically connected and mounted on a supporting structure. A photovoltaic module is a packaged, connected assembly of solar cells. Solar cells are also called photovoltaic (PV) cells, which as the name implies (photo meaning "light" and voltaic meaning "electricity"), they convert sunlight directly into electricity.

The energy of light is transmitted by photons, small packets or quanta of light. When photons are absorbed by matter (usually silicon) in the solar cell, their energy excites electrons higher energy states where the electrons can move more freely. Special treatment of the material surface during manufacturing makes the front surface of the cell more receptive to free electrons, so the electrons naturally migrate to the surface. Freeing up electrons is however only half the work of a solar cell: it then needs to herd these stray electrons into an electric current. This involves creating an electrical imbalance within the cell, which acts a bit like a slope down which the electrons will flow in the same direction. Creating this imbalance

is made possible by the internal organization of silicon. Silicon atoms are arranged together in a tightly bound structure. By squeezing small quantities of other elements into this structure, two different types of silicon are created: n-type, which has spare electrons, and p-type, which is missing electrons, leaving 'holes' in their place. When these two materials are placed side by side inside a solar cell, the n-type silicon's spare electrons jump over to fill the gaps in the p-type silicon. This means that the n-type silicon becomes positively charged, and the p-type silicon is negatively charged, creating an electric field across the cell. Because silicon is a semi-conductor, it can act like an insulator, maintaining this imbalance. As the photons smash the electrons off the silicon atoms, this field drives them along in an orderly manner, providing the electric current.

Two important quantities to characterize a solar cell are:

- Open circuit voltage (Voc): The voltage between the terminals when no current is drawn (infinite load resistance)
- Short circuit current (Isc): The current when the terminals are connected to each other (zero load resistance)

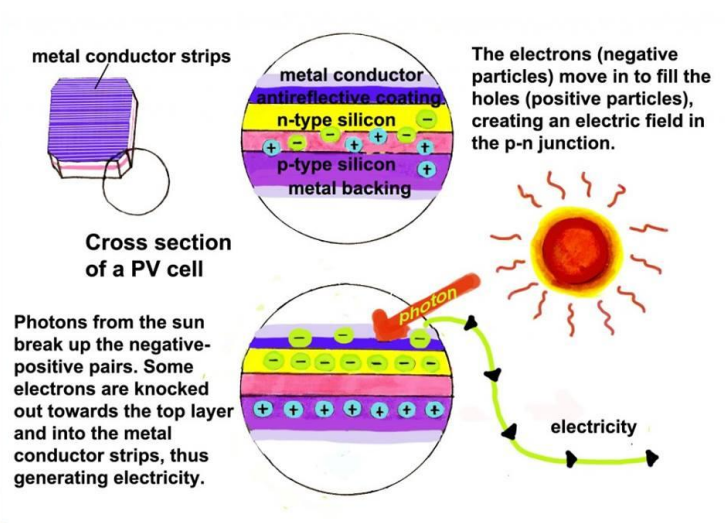

The short circuit current increase with light intensity, as higher intensity means more photons, which in turn means more electrons. Since the short circuit current Isc is roughly proportional to the area of the solar cell, the short circuit current density, $J_{sc} = I_{sc}/A$, is often used to compare solar cells.

DIFFERENT TYPES OF SOLAR PANELS

- MONOCRYSTALLINE SILICON (MONO-SILICON OR SINGLE SILICON)



Right now, these are the most efficient type of [solar panels](#). In other words, when sunlight hits these puppies, more of it turns into electricity than the other types below. As a result of their high silicon content, they're also more expensive, but you need fewer of them. That's why they're ideal for roofs. You can tell if you have a monocrystalline solar panel by its square-ish cells.

- POLYCRYSTALLINE SILICON (MULTICRYSTALLINE, MULTI-SILICON, RIBBON)



“Poly” panels have lower silicon levels than “mono” panels. In general, that makes them less expensive to produce, but they’re also slightly less efficient. The good news is that their overall construction design can often make up for the efficiency loss, so they’re also good for roofs. You can tell poly-silicon panels by their groovy mélange of silicon woven through thin rectangular conduit wires.

Thin film (amorphous silicon, cadmium telluride, copper indium gallium (di) selenide)

Everyone talks about “thin film” because they’re really inexpensive to make and they don’t mind the heat, which is all cool. Except right now, they’re very inefficient, which means you’ll see them in big solar farm projects with a lot of land, but not on your roof.

- **BIPV (BUILDING INTEGRATED PHOTOVOLTAICS)**



BIPV’s can look like real roofing tiles (solar shingles are an example). That’s nice, but good looks do cost a lot more. Second, they’re way less efficient

than conventional PV, which means you need a sunny spacious roof to make a dent in your electric bill. Finally, they may not last as long as regular panels. Right now, PURE Energies doesn't contract for BIPV systems.

- **SOLAR HOT WATER (THERMAL) PANELS**



Finally, there's another type of panel that has nothing to do with electricity. Instead of paying the gas company to heat your hot water tank, solar thermal panels produce hot water for your home and/or your pool. Some systems can even provide heat and air conditioning too. PURE Energies currently doesn't offer solar thermal deals. More information: [Solar Hot Water vs. Solar PV](#).

- SOLAR CHARGER (13.5V/5W)



Features

- ideal as 12V battery maintainer for vehicle, boat, etc.
- double glass lamination for improved protection
- with charging indicator
- 3m lead wire with crocodile battery clamps and cigarette lighter plug
- built-in blocking diode

Specifications

- type: amorphous silicon
- voltage output: 13.5V
- current output: 350mA
- power output: 5W (with charging indicator)
- color: grey
- IP rating: IP61
- dimensions: 352 x 338 x 16mm
- operating temperature: -15 to +45°

Solar Regulators

The purpose of solar regulators, or charge controllers as they are also called, is to regulate the current from the solar panels to prevent the batteries from overcharging. Overcharging causes gassing and loss of electrolyte resulting in damage to the batteries.

A solar regulator is used to sense when the batteries are fully charged and to stop, or decrease, the amount of current flowing to the battery.

Most solar regulators also include a Low Voltage Disconnect feature, which will switch off the supply to the load if the battery voltage falls below the cut-off voltage. This prevents the battery from permanent damage and

reduced life expectancy.

A solar regulator also prevents the battery from back feeding into the solar panel at night and, hence, flattening the battery.

Solar regulators are rated by the amount of current they can receive from the solar panels.

Storage

The battery is a necessary storage component in any solar system as it is used to store the electrical power in the form of a chemical reaction.

Without storage you would only have power when the sun was shining or the generator was running.

How Do Lead Acid Batteries Work?

Lead Acid batteries have changed little since the 1880's although improvements in materials and manufacturing methods continue to bring improvements in energy density, life and reliability. All lead acid batteries consist of flat lead plates immersed in a pool of electrolyte. Regular water addition is required for most types of lead acid batteries although low-maintenance types come with excess electrolyte calculated to compensate for water loss during a normal lifetime.

Battery Construction

Lead acid batteries used in the RV and Marine Industries usually consist of two 6-volt batteries in series, or a single 12-volt battery. These batteries are constructed of several single cells connected in series each cell produces approximately 2.1 volts. A six-volt battery has three single cells, which when fully charged produce an output voltage of 6.3 volts. A twelve-volt battery has six single cells in series producing a fully charged output voltage of 12.6 volts.

A battery cell consists of two lead plates a positive plate covered with a paste of lead dioxide and a negative made of sponge lead, with an insulating material (separator) in between. The plates are enclosed in a plastic battery case and then submersed in an electrolyte consisting of water and sulfuric acid (see figure # 1). Each cell is capable of storing 2.1 volts.

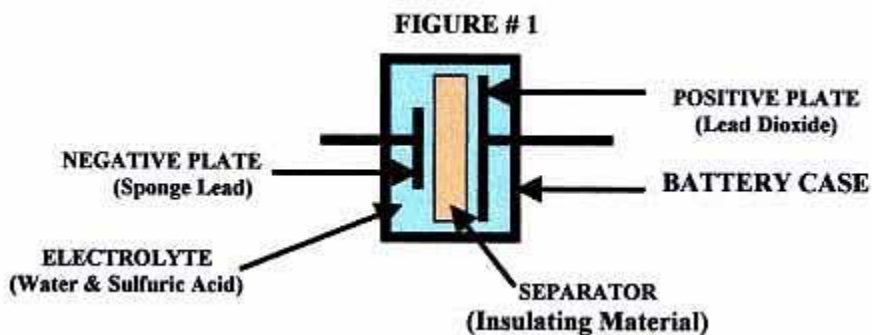

In order for lead acid cell to produce a voltage, it must first receive a (forming) charge voltage of at least 2.1-volts/cell from a charger. Lead acid batteries do not generate voltage on their own; they only store a charge from another source. This is the reason lead acid batteries are called storage batteries, because they only store a charge. The size of the battery plates and amount of electrolyte determines the amount of charge lead acid batteries can store. The size of this storage capacity is described as the amp

hour (AH) rating of a battery. A typical 12-volt battery used in a RV or marine craft has a rating 125 AH, which means it can supply 10 amps of current for 12.5 hours or 20-amps of current for a period of 6.25 hours. Lead acid batteries can be connected in parallel to increase the total AH capacity.

In figure # 2 below, six single 2.1-volt cells have been connected in series to make the typical 12-volt battery, which when fully charged will produce a total voltage of 12.6-volts.

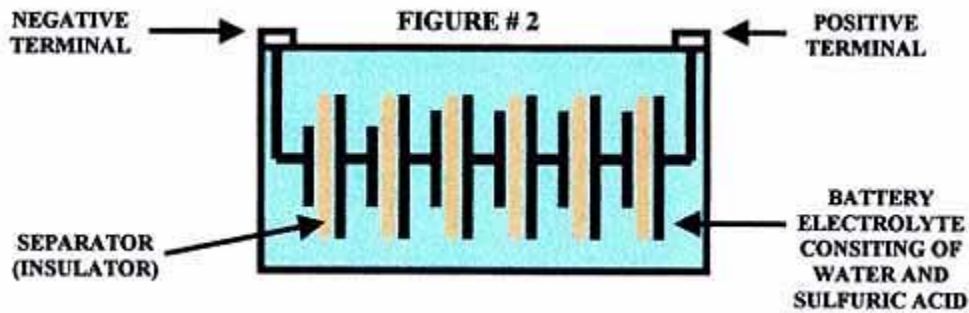

Lead Acid Batter Discharge Cycle

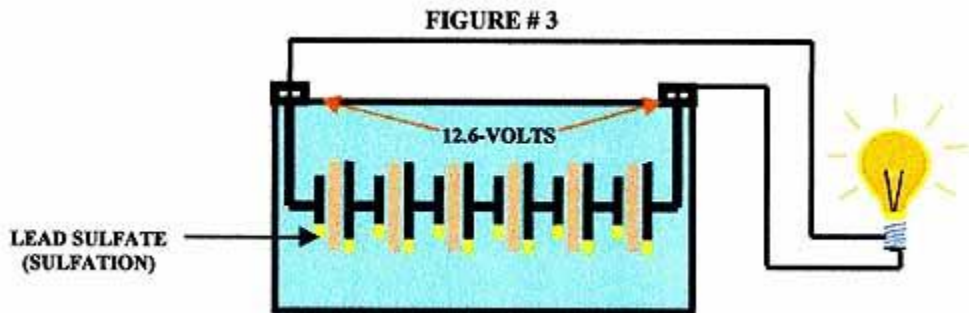

In figure # 3, above a fully charged battery is connected to a load (light bulb) and the chemical reaction between sulfuric acid and the lead plates produces the electricity to light the bulb. This chemical reaction also begins to coat both positive and negative plates with a substance called lead sulfate also known as sulfation (shown as a yellow build-up on plates). This build-up of lead sulfate is normal during a discharge cycle. As the battery continues to discharge, lead sulfate coats more and more of the plates and battery voltage begins to decrease from fully charged state of 12.6-volts (figure # 4).

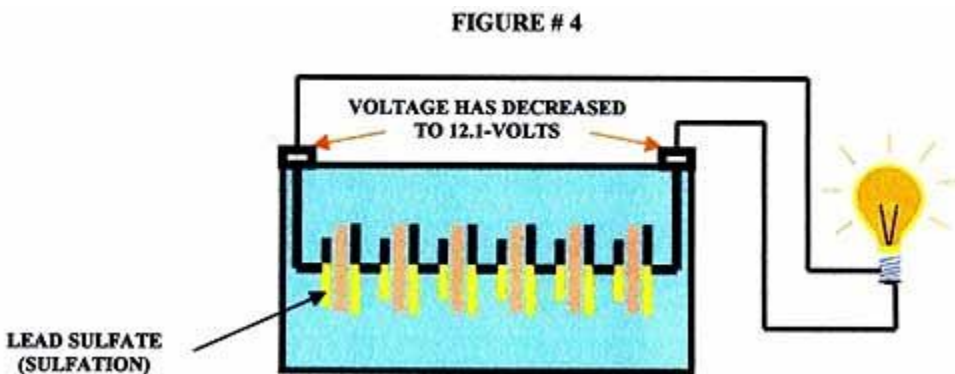

In figure # 5 the battery is now fully discharged, the plates are almost completely covered with lead sulfate (sulfation) and voltage has dropped to 10.5-volts.

NOTE: Discharging a lead acid battery below 10.5 volts will severely damage it!

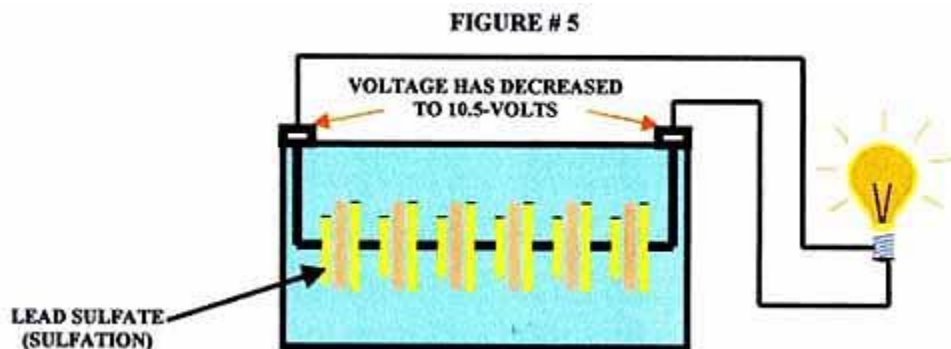

Lead Acid Battery Recharge Cycle

The most important thing to understand about recharging lead acid batteries is that a converter/charger with a single fixed output voltage will not properly recharge or maintain your battery. Proper recharging and maintenance requires an intelligent charging system that can vary the charging voltage based on the state of charge and use of your RV or Marine battery. Progressive Dynamics has developed intelligent charging systems that solve battery problems and reduce battery maintenance.

The discharged battery shown in figure # 6 on the next page is connected to a converter/charger with its output voltage set at 13.6-volts. In order to recharge a 12-volt lead acid battery with a fully charged terminal voltage of 12.6-volts, the charger voltage must be set at a higher voltage. Most converter/chargers on the market are set at approximately 13.6-volts. During the battery recharge cycle lead sulfate (sulfation) begins to reconvert to lead and sulfuric acid.

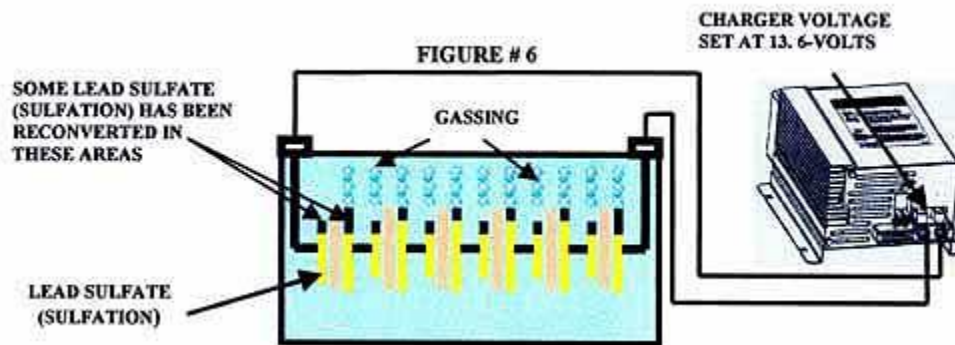

During the recharging process as electricity flows through the water portion of the electrolyte and water, (H_2O) is converted into its original elements, hydrogen and oxygen. These gasses are very flammable and the reason your RV or Marine batteries must be vented outside. Gassing causes water loss and therefore lead acid batteries need to have water added periodically. Sealed lead acid batteries contain most of these gasses

allowing them to recombine into the electrolyte. If the battery is overcharged pressure from these gasses will cause relief caps to open and vent, resulting in some water loss. Most sealed batteries have extra electrolyte added during the manufacturing process to compensate for **some water loss.**

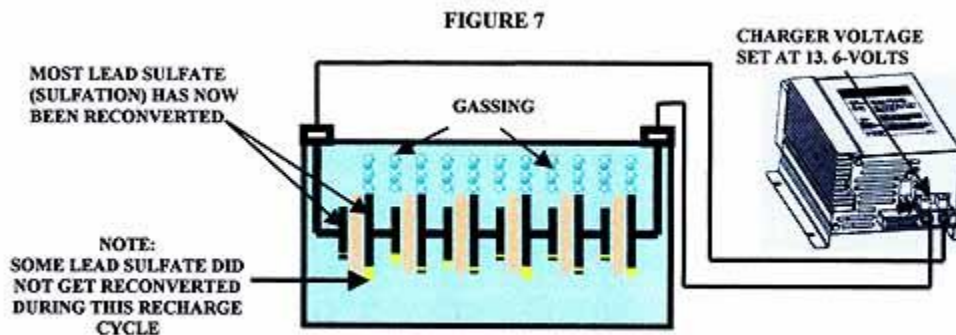



Chapter 3:
Open
Source
Technologies

Open source technologies

Open source technology is one of the most often misunderstood and misused terms. Users often think open source is synonymous with free. With the relatively recent rise of the Internet's influence on production and development of software, open source has become a popular vehicle to obtain widespread use and support of some very popular software.

Open source technology is defined as the production and development philosophy of allowing end users and developers to not only see the source code of software, but modify it as well. Open source is not limited to software, although it is the most popular, lending itself well to manipulation of its code and add-ons. Open source philosophies have been applied to everything from medicine to soft drink formulas such as Open source colas – cola soft drinks, similar to Coca-Cola and Pepsi, whose recipe is open source and developed by volunteers.

Open-source software is software whose source code is published and made available to the public, enabling anyone to copy, modify and redistribute the source code without paying royalties or fees. The Linux operating system is a one of the best-known examples of open source software technology. Early instances of the free sharing of source code include



IBM's source releases of its operating systems and other programs in the 1950s and 1960s.

Open-source hardware is hardware whose initial specification, usually in a software format, are published and made available to the public, enabling anyone to copy, modify and redistribute the hardware and source code without paying royalties or fees. An example would be Openmoko, a family of open-source mobile phones, including the hardware specification and the operating system.

How Open Source Works

Open source provides a transparent platform upon which anyone with the skills to do so can add to the development and production of the software either for release as a new incarnation of the software for others to use or for strictly in-house development only. Most money made from open source software comes in the form of support for the software technology and its many additions, add-ons, and modifications that often ensue. Yet outlined in most open source license agreements, ownership of the software can never transfer to anyone who modifies the software. This usually makes it impossible for a developer to take open source software, modify it, and then sell it, so the software is not free in the sense that the end user can do whatever he/she wants to it including selling it.

Open source microcontroller

An **embedded system** is a computer system with a dedicated function within a larger mechanical or electrical system, often with real-time computing constraints. It is *embedded* as part of a complete device often including hardware and mechanical parts. To control our system we will use a **microcontroller**, which is a small computer on a single integrated circuit containing a processor core, memory, and programmable input/output peripherals. Microcontrollers are designed for embedded applications, in contrast to the microprocessors used in personal computers or other general purpose applications. Like all good things, this powerful component is basically very simple. It is made by mixing tested and high-quality "ingredients" (components) as per following receipt:

1. The simplest computer processor is used as the "brain" of the future system.
2. Depending on the taste of the manufacturer, a bit of memory, a few A/D converters, timers, input/output lines etc. are added
3. All that is placed in some of the standard packages.
4. Simple software able to control it all and which everyone can easily learn about has been developed.

There are many platforms that can be used for embedded systems. Three models are the Arduino, Raspberry Pi and BeagleBone. Those three are all readily available, affordable and about the same size (just larger than 2" x 3").



Left to right: (Arduino Uno, BeagleBone, Raspberry Pi)

The Arduino Uno is a staple for the maker community. Arduinos come in various sizes and flavors, but we chose the Arduino Uno as an example of the prototypical Arduino for comparison. It has an easy to use development environment, an avid user base and is designed to be easy to interface all sorts of hardware to. The Raspberry Pi is the newcomer to the game. It isn't really an embedded computer. It is actually a very inexpensive full-on desktop computer. The BeagleBone is the perhaps the least known of these platforms, but an incredibly capable board worthy of consideration for many projects. It is a powerful Linux computer that fits inside an Altoid's mint container.

Name	Arduino Uno	Raspberry Pi	BeagleBone
Model Tested	R3	Model B	Rev A5
Price	\$29.95	\$35	\$89
Size	2.95"x2.10"	3.37"x2.125"	3.4"x2.1"
Processor	ATMega 328	ARM11	ARM Cortex-A8
Clock Speed	16MHz	700MHz	700MHz
RAM	2KB	256MB	256MB
Flash	32KB	(SD Card)	4GB(microSD)
EEPROM	1KB		
Input Voltage	7-12v	5v	5v
Min Power	42mA (.3W)	700mA (3.5W)	170mA (.85W)
Digital GPIO	14	8	66
Analog Input	6 10-bit	N/A	7 12-bit
PWM	6		8
TWI/I2C	2	1	2
SPI	1	1	1
UART	1	1	5
Dev IDE	Arduino Tool	IDLE, Scratch, Squeak/Linux	Python, Scratch, Squeak, Cloud9/Linux
Ethernet	N/A	10/100	10/100
USB Master	N/A	2 USB 2.0	1 USB 2.0
Video Out	N/A	HDMI, Composite	N/A
Audio Output	N/A	HDMI, Analog	Analog

Comparing the three platforms.

Why use Arduino?

We chose to use arduino for the following reasons:

1. It is an **open source** project with umpteen, different kits, shield's. It is a very accessible platform with extended and customized possibilities for both software and hardware sides.
2. It has the largest **community** of users, the most tutorials and sample projects.
3. The Arduino makes it the easiest of any of the boards to **interface** to external hardware and sensors. There are different versions of the board that operate at different voltages (3.3v vs 5v) to make it easier to connect to external devices.

4. It has a much simpler **microcontroller-based** approach making it more suitable for applications which demand a very high degree of reliability.
5. It has a **friendly programming environment**, with easy programming using a C-like programming language. It comes supplied with a friendly Arduino development environment (IDE) and libraries which have been designed for ease of use and to support "*non-programmers*", and within minutes of installing these you can be blinking LEDs and reading temperature sensors.
6. It has **low power consumption** (<0.5 W), capable of even running micro amps with very low clock. It is made to be running 24 hrs a day, all year and is suited for permanent installations. It will do it's job day and night for years without requiring any updates. That also makes it suitable for battery powered applications.
7. It is **inexpensive**, around 30 euro per board and comes with free authoring software
8. Has a **cross-platform** - The Arduino software runs on Windows, Macintosh OSX, and Linux operating systems. Most microcontroller systems are limited to Windows.

Raspberry Pi and Beaglebone have their advantages such as including Ethernet interfaces and USB, enabling connecting them to the network relatively painlessly, unlike the arduino which even with a shield that includes the ability to connect to Ethernet, has fairly limited access to the networking functions. Yet for our system purpose we found that the arduino advantages make it the most suitable.

Why Arduino Mega?

Some shields do not work on the Mega2560 because the SPI pins and I2C (TWI) pins are not in the same place as on the Uno, but this is not important for our project since we will not be using any shields. We decided to use Arduino Mega as it has more hardware serial ports, more timers, and more I/O pins (Arduino Uno has 20 I/O pins, while the Mega has 70) and we needed the larger number of pins due to the various control parameters in our project.

Although Arduino Mega2560 is of almost double the price, using two Arduino Uno boards will almost cost the same and it will require using Serial Peripheral Interface (SPI), which is a synchronous serial data protocol used by microcontrollers for communicating with one or more peripheral devices quickly over short distances. It can also be used for communication between two microcontrollers.

Arduino Mega2560

The Arduino Mega 2560 is a microcontroller board based on the ATmega2560 datasheet. It has 54 digital input/output pins (of which 15 can be used as PWM outputs), 16 analog inputs, 4 UARTs (hardware serial ports), a 16 MHz crystal oscillator, a USB connection, a power jack, an ICSP header, and a reset button. It is an update to the Arduino Mega, which it replaces.

Summary

Microcontroller	ATmega2560
Operating Voltage	5V
Input Voltage (recommended)	7-12V
Input Voltage (limits)	6-20V
Digital I/O Pins	54 (of which 15 provide PWM output)
Analog Input Pins	16
DC Current per I/O Pin	40 mA
DC Current for 3.3V Pin	50 mA
Flash Memory	256 KB of which 8 KB used by bootloader
SRAM	8 KB
EEPROM	4 KB
Clock Speed	16 MHz

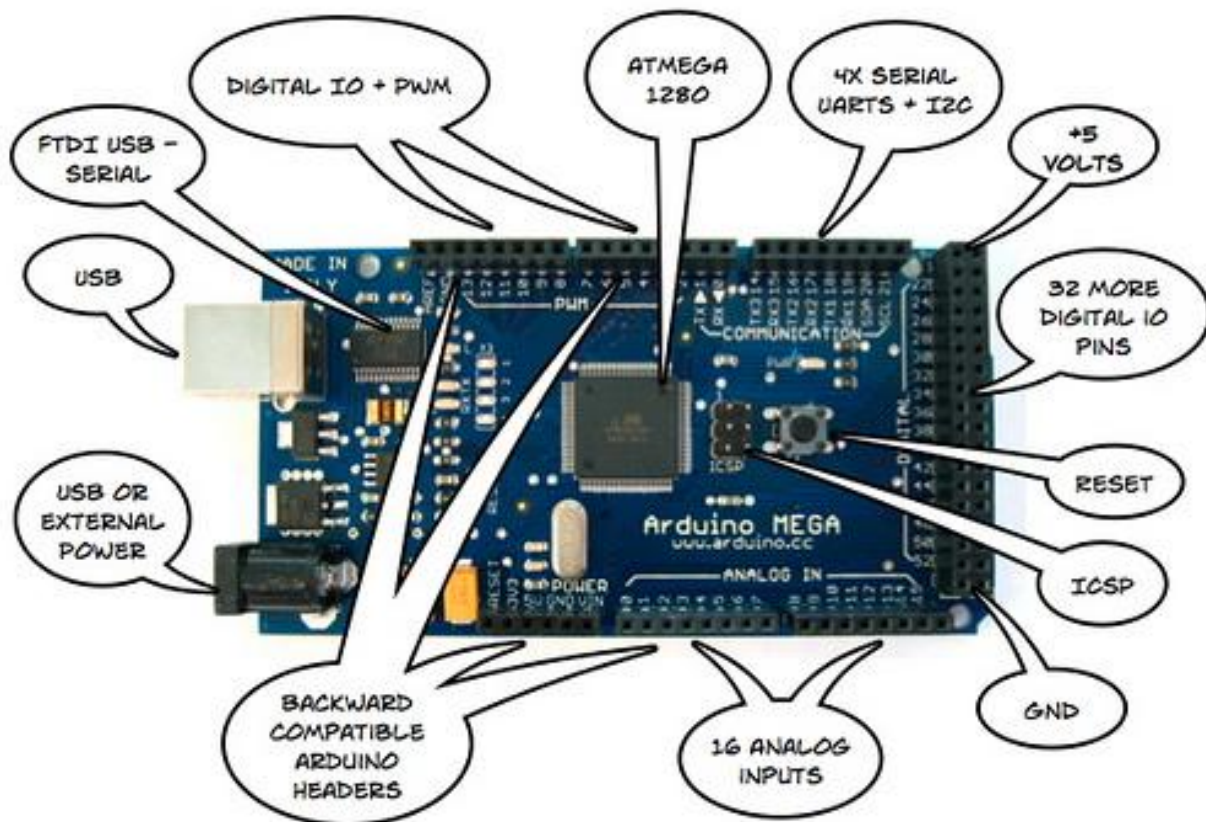

Power:

The Arduino Mega can be powered via the USB connection or with an external power supply. The power source is selected automatically.

External (non-USB) power can come either from an AC-to-DC adapter (wall-wart) or battery. The adapter can be connected by plugging a 2.1mm center-positive plug into the board's power jack. Leads from a battery can be inserted in the Gnd and Vin pin headers of the POWER connector.

The board can operate on an external supply of 6 to 20 volts. If supplied with less than 7V, however, the 5V pin may supply less than five volts and the board may be unstable. If using more than 12V, the voltage regulator may overheat and damage the board. The recommended range is 7 to 12 volts.

The power pins are as follows:

- **VIN.** The input voltage to the Arduino board when it's using an external power source (as opposed to 5 volts from the USB connection or other regulated power source). You can supply voltage through this pin, or, if supplying voltage via the power jack, access it through this pin.
- **5V.** This pin outputs a regulated 5V from the regulator on the board. The board can be supplied with power either from the DC power jack (7 - 12V), the USB connector (5V), or the VIN pin of the board (7-12V). Supplying voltage via the 5V or 3.3V pins bypasses the regulator, and can damage your board. We don't advise it.

- **3V3.** A 3.3 volt supply generated by the on-board regulator. Maximum current draw is 50 mA.
- **GND.** Ground pins.
- **IOREF.** This pin on the Arduino board provides the voltage reference with which the microcontroller operates. A properly configured shield can read the IOREF pin voltage and select the appropriate power source or enable voltage translators on the outputs for working with the 5V or 3.3V.

INPUT AND OUTPUT

Each of the 54 digital pins on the Mega can be used as an input or output, using `pinMode()`, a function which configures pin behavior. They operate at 5 volts. Each pin can provide or receive a maximum of 40 mA and has an internal pull-up resistor (disconnected by default) of 20-50 kOhms. The `digitalWrite()` and `digitalRead()` functions are used to send digital output and receive digital input. Some of the digital pins have additional specialized functions.

The 16 analog input pins, each provide 10 bits of resolution (i.e. 1024 different values). By default they measure from ground to 5 volts, though is it possible to change the upper end of their range using the AREF pin and `analogReference()` function. Receiving analog input is done using the `analogRead()` function.

Arduino analog pins are only used to receive analog input; there are no pins that give out true analog output. The Arduino `analogWrite()` rather puts out a signal that pulses back and forth between 0 and 5 volts rapidly.

The percentage of the time it is ON vs Off allows it to simulate the effect of analog signals in some applications. This manipulation of digital signals is called PWM (Pulse Width Modulation). There are 15 digital pins that are specialized to sending out PWM signals. PWM switching must be done at a frequency too high to be discerned by the human eye. By default, most Arduino pwm outputs are set to about 490Hz or 980Hz. We can change that frequency using the `setPwmFrequency()` instruction, but timers may be used by other functions and libraries, thus changing PWM frequencies can have unexpected side effects. Also, PWM frequencies are tied together in pairs of pins. If one in a pair is changed, the other is also changed to match.

Duty Cycle - When the signal is high, we call this “on time”. To describe the amount of “on time”, we use the concept of duty cycle. Duty cycle is measured in percentage. The percentage duty cycle specifically describes the percentage of time a digital signal is on over an interval or period of time. This period is the inverse of the frequency of the waveform.

If a digital signal spends half of the time on and the other half off, we would say the digital signal has a duty cycle of 50% and resembles an ideal square wave. If the percentage is higher than 50%, the digital signal spends more time in the high state than the low state and vice versa if the duty cycle is less than 50%. At the right is a graph that illustrates these three scenarios.

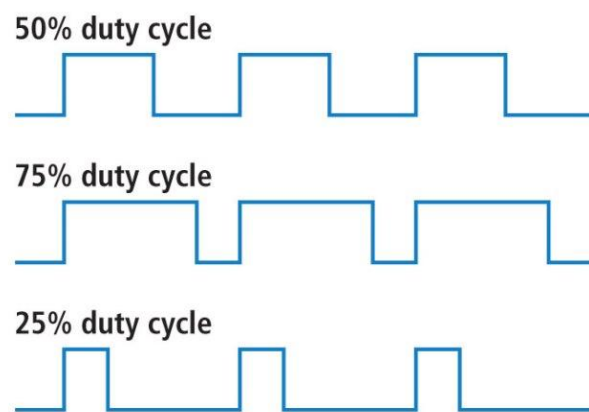

We will need to use PWM for the following controls:

1. Variation of LED brightness:

You can control the brightness of an LED by adjusting the duty cycle. The frequency of the square wave does need to be sufficiently high enough when controlling LEDs to get the proper dimming effect. A 20% duty cycle wave at 1 Hz will be obvious that it's turning on and off to your eyes meanwhile, 20% duty cycle at 100 Hz or above will just look dimmer than fully on. Essentially, the period can't be too large if you're aiming for a dimming effect with the LEDs.

2. Servo motor control:

It's not ideal to run a motor with a varying voltage, so most controllers use PWM to fake a varied voltage for motor control. By turning the power on and off very rapidly, the average power to the motor goes up or down, changing its speed without varying the voltage (that is, except for either full on or completely off).

Servos have a shaft that turns to specific position based on its control line. Frequency/period are specific to controlling a specific servo. A typical servo motor expects to be updated every 20 ms with a pulse between 1 ms and 2 ms, or in other words, between a 5 and 10% duty cycle on a 50 Hz waveform.

With a 1.5 ms pulse, the servo motor will be at the natural 90 degree position, with a 1 ms pulse, the servo will be at the 0 degree position, and with a 2 ms pulse, the servo will be at 180 degrees.

You can obtain the full range of motion by updating the servo with any value in between.

By default, most Arduino PWM outputs are set to about 490Hz or 980Hz. These frequencies work quite well with small dc brushed motors but can cause unwanted noise or reduce motor torque in some cases.

Considerations for changing frequencies:

- Many motor controllers cannot work at high frequencies and can short circuit when you change to high frequencies.
- High frequencies increase inductive reactance of the motor windings. This can increase heat and decrease motor torque.
- Timers may be used by other functions and libraries. Changing PWM frequencies can have unexpected side effects.

There is a library specified for controlling servo motors, to use it we write “`#include <Servo.h>`” in the library section of the code. We must create a servo object representing the motor of type “Servo” (e.g. `Servo myservo;`)

Basic Servo.h instructions used:

- `attach()`
Used to attach the the servo object to a pin. It is used in the setup portion of the code.

Syntax `:servo.attach(pin, min, max)`

Parameters:

- `servo`: a variable of type Servo
`pin`: the number of the pin that the servo is attached to
`min` (optional): the pulse width, in microseconds, corresponding to the minimum (0-degree) angle on the servo(defaults to 544)
`max` (optional): the pulse width, in microseconds,

corresponding to the maximum (180-degree) angle on the servo (defaults to 2400)

- write()

Used to write a value to the servo, controlling the shaft accordingly. On a standard servo, this will set the angle of the shaft (in degrees), moving the shaft to that orientation. On a continuous rotation servo, this will set the speed of the servo (with 0 being full-speed in one direction, 180 being full speed in the other, and a value near 90 being no movement).

Syntax: `servo.write(angle)`

Parameters:

`servo`: a variable of type `Servo`

`angle`: the value to write to the servo, from 0 to 180

To control motor speed, we can increment servo angle in a loop, following it with a delay (in milliseconds), using the instruction “`delay()`”. The larger the delay, the slower the movement.

Example:

```
while (angle!=90) {  
    angle = ++angle; //increments angle  
    servo.write(angle);  
    delay(20); //  
}
```

Interrupt

Interrupt is used so that the program can be interrupted according to a certain condition. We will use this to light the LEDs whenever the infrared output changes (which mean a car has passed), if it is night time.

Syntax: `attachInterrupt(interrupt, ISR, mode)`

Parameters:

interrupt: Number of interrupt, each interrupt is attached to a certain pin (this pin will be used for the interrupt condition, in our project we will attach the infrared output to this pin after having used a voltage divider to decrease the volt).

ISR: The ISR function to call when interrupt occurs, it must take no input and give no output

mode: Defines the condition that triggers the interrupt.

Four constants are predefined as valid values:

- **LOW** to trigger the interrupt whenever the pin is low,
- **CHANGE** to trigger the interrupt whenever the pin changes value
- **RISING** to trigger when the pin goes from low to high,
- **FALLING** for when the pin goes from high to low.

Getting started

- Get the latest version of the Arduino environment from the [download page](#).

When the download finishes, unzip the downloaded file. Make sure

to preserve the folder structure. Double-click the folder to open it. There should be a few files and sub-folders inside.

- Plug in your board and wait for Windows to begin its driver installation process. After a few moments, the process will fail, despite its best efforts
- Click on the Start Menu, and open up the Control Panel.
- While in the Control Panel, navigate to System and Security. Next, click on System. Once the System window is up, open the Device Manager.
- Look under Ports (COM & LPT). You should see an open port named "Arduino UNO (COMxx)". If there is no COM & LPT section, look under "Other Devices" for "Unknown Device".
- Right click on the "Arduino UNO (COMxx)" port and choose the "Update Driver Software" option.
- Next, choose the "Browse my computer for Driver software" option.
- Finally, navigate to and select the driver file named "**arduino.inf**", located in the "Drivers" folder of the Arduino Software download (not the "FTDI USB Drivers" sub-directory). If you are using an old version of the IDE (1.0.3 or older), choose the Uno driver file named "**Arduino UNO.inf**".
- Windows will finish up the driver installation from there.
- Double-click the Arduino application.
- Make sure to select the entry in the **Tools > Board** menu that corresponds to your Arduino (Arduino Mega 2560)

- Select the serial device of the Arduino board from the Tools | Serial Port menu. This is likely to be **COM3** or higher (**COM1** and **COM2** are usually reserved for hardware serial ports). To find out, you can disconnect your Arduino board and re-open the menu; the entry that disappears should be the Arduino board. Reconnect the board and select that serial port.
- Now, simply click the "Upload" button in the environment to upload the opened/written program to the Arduino board. Wait a few seconds - you should see the RX and TX leds on the board flashing. If the upload is successful, the message "Done uploading." will appear in the status bar.

General code structure

```
//libraries and variables
```

```
void setup(){  
}
```

```
void loop(){  
}
```

- **Libraries and global variables**

Here we declare all libraries used as well as any global variables.

- **setup()**

Here we layout the initial conditions for the program so that the Arduino knows what kind of work it's going to be doing. In this part we usually initialize variables and set pin modes using "pinMode()" instruction. The setup function will only run once, after each powerup or reset of the Arduino board.

- **loop()**

This function does precisely what its name suggests; it loops consecutively, allowing your program to change and respond. It is used to actively control the Arduino board.



Chapter 4:

Mechanical

System

Mechanical System

The mechanical system is the system that combines all the mechanical parts of the project. A mechanical system manages power to accomplish a task that involves forces and movement.

The *mechanism* of a mechanical system is assembled from components called *machine elements*. These elements provide structure for the system and control its movement.

The structural components are, generally, the frame members, bearings, splines, springs, seals, fasteners and covers. The shape, texture and color of covers provide a styling and operational interface between the mechanical system and its users.

The assemblies that control movement are called *mechanisms*. Mechanisms are generally classified as gears and gear trains, which includes belt drives and chain drives, cam and follower mechanisms, and linkages, though there are other special mechanisms such as clamping linkages, indexing mechanisms, escapements and friction devices such as brakes and clutches.

Gear or Cogwheel

is a rotating machine part having cut *teeth*, or *cogs*, which *mesh* with another toothed part in order to transmit torque, in most cases with teeth on the one gear being of identical shape, and often also with that shape on

the other gear. Two or more gears working in tandem are called a *transmission* and can produce a mechanical advantage through a gear ratio and thus may be considered a simple machine. Geared devices can change the speed, torque, and direction of a power source. The most common situation is for a gear to mesh with another gear; however, a gear can also mesh with a non-rotating toothed part, called a rack, thereby producing translation instead of rotation.

The gears in a transmission are analogous to the wheels in a crossed belt pulley system. An advantage of gears is that the teeth of a gear prevent slippage.

When two gears mesh, and one gear is bigger than the other (even though the size of the teeth must match), a mechanical advantage is produced, with the rotational speeds and the torques of the two gears differing in an inverse relationship.



Spur

gears or *straight-cut gears* are the simplest type of gear used. They consist of a cylinder or disk with the teeth projecting radially, and although they are not straight-sided in form (they are usually of special form to achieve constant drive ratio, mainly involutes), the edge of each tooth is straight and aligned parallel to the axis of rotation. These gears can be meshed together correctly only if they are fitted to parallel shafts.

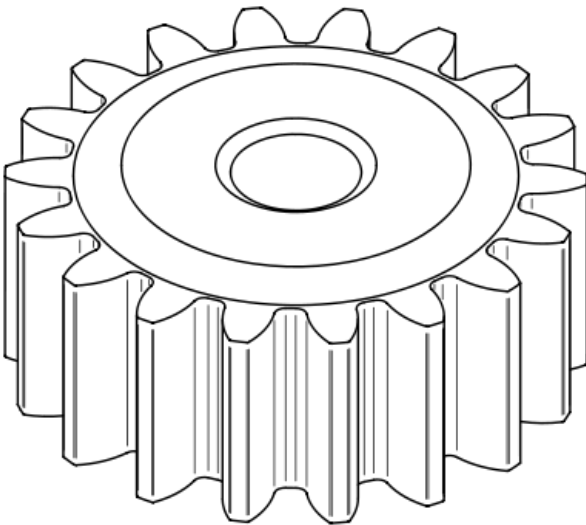

Basic components used

- Base gear and panel mount components
- Base gear shaft, which is the axle of the gear, providing the rotation that allows one gear to engage with and turn another.
- Panel bracket
- Horizontal servo gear
- Vertical servo gear
- LDR divider
- Tracker base

In this project the intension was to use **Teflon** for the mechanical design components, but due to budget limitation and weight excess we decided to use another product.

What is Teflon?

Teflon is the brand name of a compound discovered by Roy J. Plunkett that was introduced as a commercial product in 1946. Teflon is polytetrafluoroethene (PTFE). It is also used as the trade name for a polymer with similar properties, perfluoroalkoxy polymer resin (PFA).

Teflon is the plastic with the lowest coefficient of friction, which is why it was our first consideration of component material. It is also used as a non-

stick coating for pans and other cookware. Teflon is very un-reactive, and so is often used in containers and pipe work for reactive chemicals.



Instead of Teflon another product was used and it is **Artelon**.

What is Artelon?

Artelon is a chemically cross linked polyethylene foam available in roll and sheet form. Artelon differs from Softlon foam in that it has a larger cell structure and rougher surface. It is lightweight, flexible and comes in a wide range of densities, widths and lengths. Being made by the continuous process, it is easily and cost effectively formed into composite products through lamination of fabrics and other materials.

Artelon can be supplied in a variety of grades for:

Sealing against water, air, dust, etc.

Impact / vibration dampening

Dynamic pressure absorption (expansion)

Polyolefin foam: Artelon is a closed-cell, chemically cross-linked polyethylene foam available in roll or sheet form. Superior mechanical and physical properties make Artelon suitable for applications that require low water absorption, thermal and chemical insulation, shock absorption, buoyancy and cushioning. Artelon is lightweight, durable, and easily fabricated for a variety of applications in building & construction, automotive, sundry goods, and more. Fire retardant and low thermal conductivity properties make Artelon especially appropriate.

Why Artelon?

Artelon was used rather than Teflon because it was cheaper and mechanical-wise there is not a big difference between them.

Final prototype mechanical design

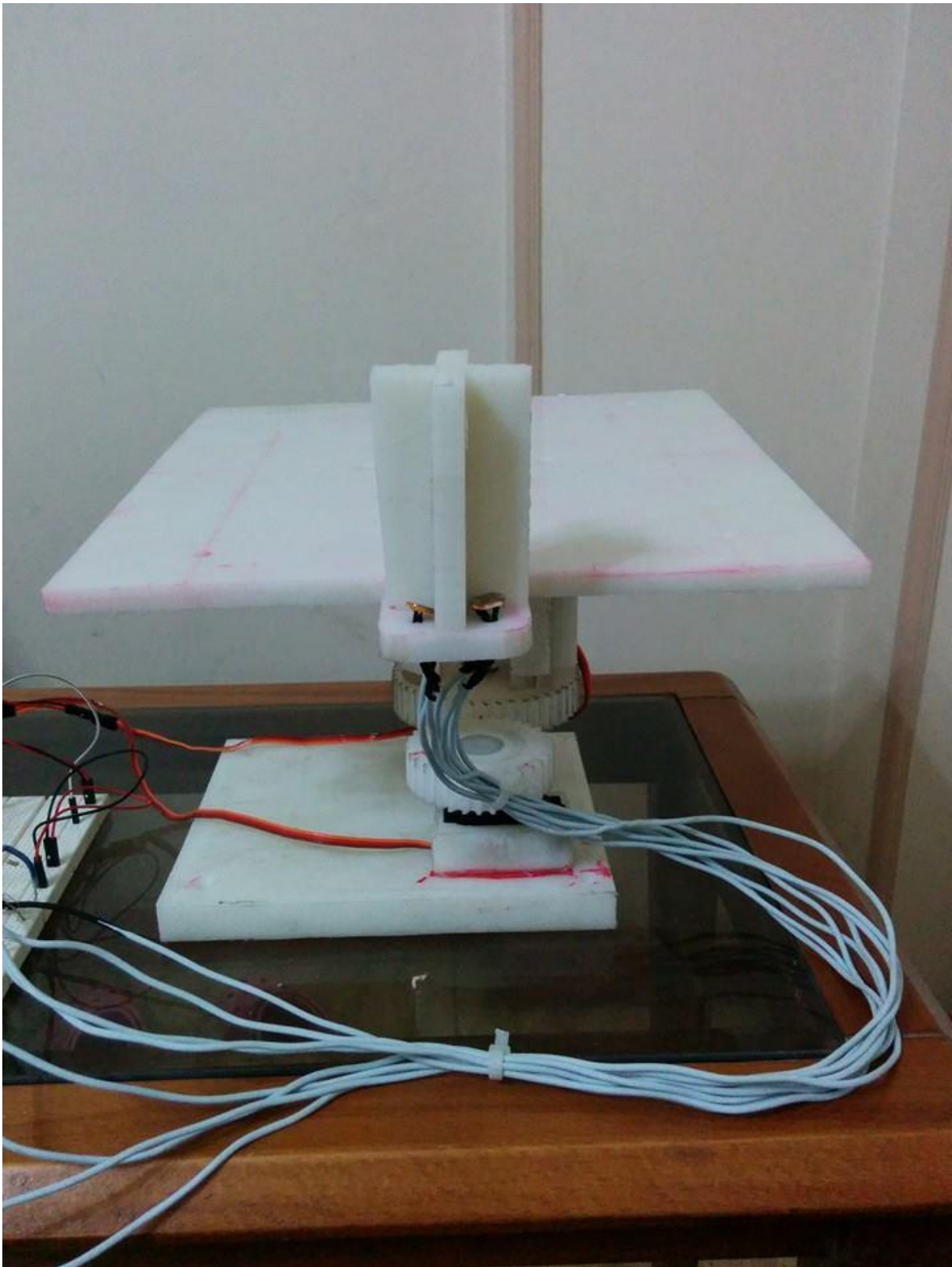

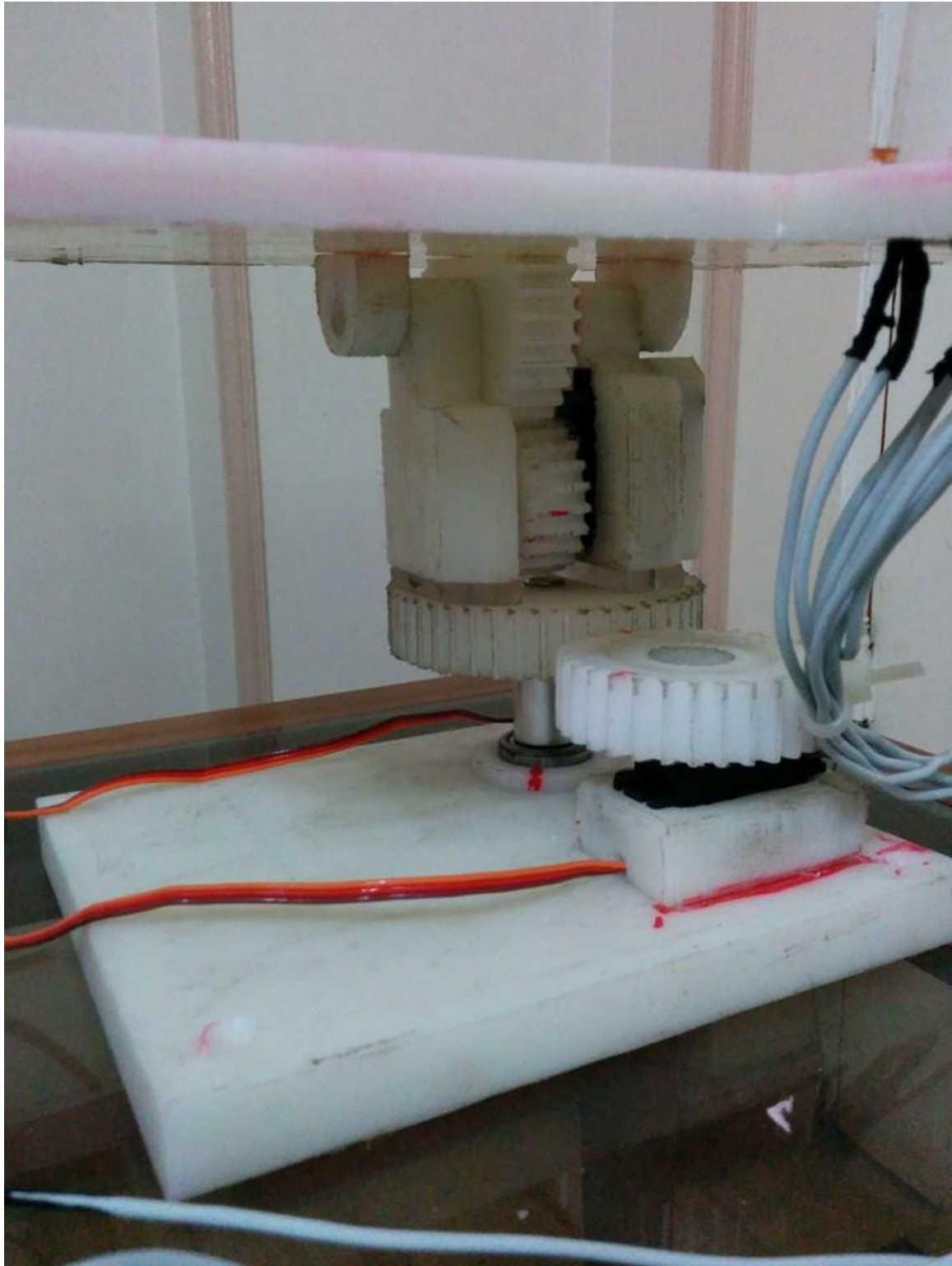



Chapter 5:

Hardware

Components

Preview:

As you are aware by now the system consists of the previously mentioned hardware components (Solar panel, solar regulator, rechargeable battery, Arduino), some basic components such as the breadboard and resistors, and other hardware components which will be discussed in this chapter.

The components that make up the device are as follows:

Light Source:

The light source is the analog input signal into the system. It will be in the form of a halogen light bulb or the sun.





Photoresistors:

A photoresistor or light-dependent resistor (LDR) or photocell is a light-controlled variable resistor. The resistance of a photoresistor decreases with increasing incident light intensity; in other words, it exhibits photoconductivity. A photoresistor can be applied in light-sensitive detector circuits, and light- and dark-activated switching circuits.

A photoresistor is made of a high resistance semiconductor. In the dark, a photoresistor can have a resistance as high as a few megaohms ($M\Omega$), while in the light, a photoresistor can have a resistance as low as a few hundred ohms. If incident light on a photoresistor exceeds a certain frequency, photons absorbed by the semiconductor give bound electrons enough energy to jump into the conduction band. The resulting free electrons (and their hole partners) conduct electricity, thereby lowering resistance. The resistance range and sensitivity of a photoresistor can substantially differ among dissimilar devices. Moreover, unique photoresistors may react substantially differently to photons within certain wavelength bands.

We are using four Light Dependent Resistors as Light intensity measurement sensor.

These Four photoresistors will be placed in strategic locations around a base, allowing the Arduino to identify which photoresistor is sensing the highest intensity of light. The solar panel moves to the high light density area through servo motors

Two LDR's are connected in series for both horizontal and vertical movement i.e. one leg of each LDR is tied together, remaining leg of one LDR is connected to power supply and that of other is to ground. This makes voltage divider circuit which divides the voltage equally across two LDRs.

When light on both LDRs is same, their resistance is nearly same. Hence the voltage between common point and the ground is nearly half of the biased voltage i.e. threshold voltage. When light on the ground side of LDR is more, its resistance decreases. Thus common point voltage falls below threshold voltage. Similarly, when light on power side LDR is more, the common point voltage crosses the threshold value.

LDR is a passive transducer hence we will use potential divider circuit to obtain corresponding voltage value from the resistance of LDR.

LDRs resistance is inversely proportional to the intensity of light falling on it i.e. Higher the intensity or brightness of light the Lower the resistance and vice versa.

The intensity of light will be constant during the day and night. But it will change drastically most probably between 5-7 AM/PM. Typical plots of Intensity & Variation of resistance of the LDR are given below.

Time Response of the Intensity of light:

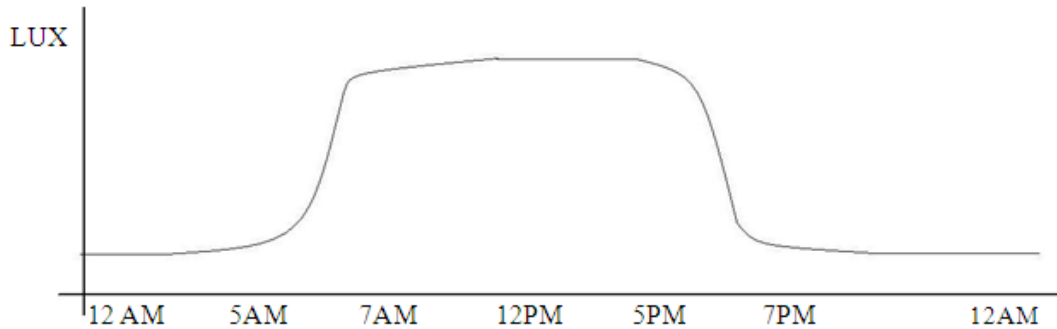

Time Response of the LDR

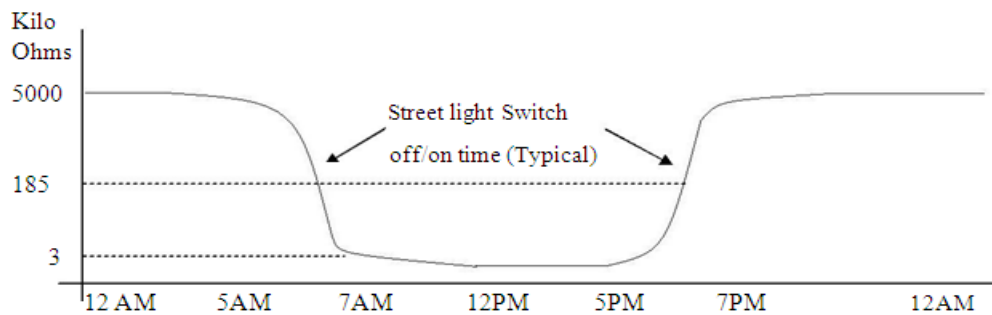

Graph showing time response of LDR

& street lights switch ON/OFF

This fig shows the photoresistor (LDR)

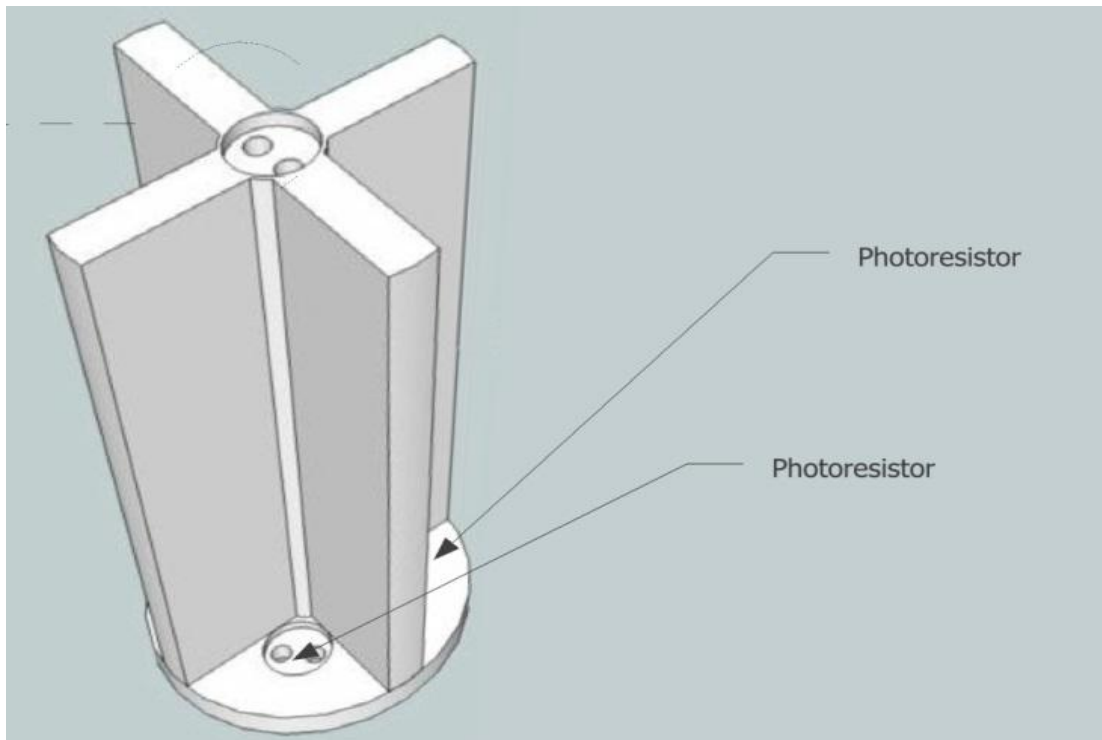
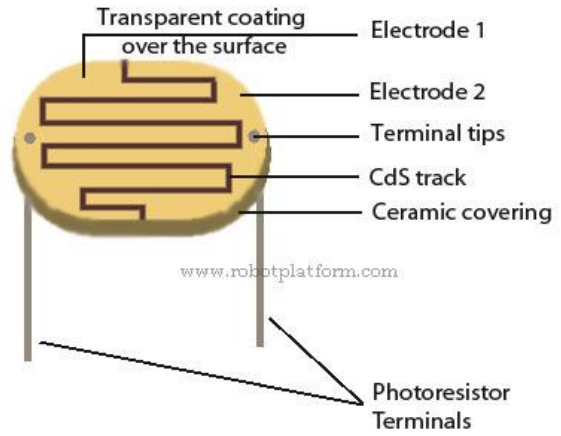

This fig shows Photoresistors placement

Note that :

In the automation of streetlights, the control action based upon (i) Intensity & (ii) Time. In the Intensity, based method control action is done considering the light intensity. The lights will glow whenever there is less intensity and puts off when the light intensity is more. However, the disadvantage we encounter here is, during cloudy days the intensity is very less all over the day. Here the lights always glow. Loss of power is more. There is always chance of false triggering in case of lightening also. Therefore, this is not recommendable.

When coming to the Time based, we fix up the time during which the lights should be On/Off. However, the disadvantage here is during the summer the days are long and during the winter, the nights are long. So the lights should be switched off quickly during summers and switched off lately during winters in the morning times. In the evening times it takes vice versa. But the time is preset, it can't be changed.

Here the problem arises and function irregular of seasons.

In order to overcome these disadvantages, we are controlling the streetlights using the micro-controller where the two parameters are taken into account. Here we are interfaced the LDR and RTC to the micro-controller, where the control action is taken through the program written to the micro-controller using the both parameters at a time. This is easy to operate and we can rewrite the program according to our requirements.

That's why we will need to use the RTC along with the LDR the intensity, less is the resistance and vice versa. In almost all ,the LDR the resistance changes from millions of ohms to hundreds of ohms under maximum illumination. The dark resistance of LDR used here is about 5 MΩ.

Electronic Switch:

An electronic switch is essentially just a switch that uses an electrical current, to turn on. There are almost as many types of mechanical switches in the world as there are idiots. Well, maybe not. But switches do come in a large array of sizes, types, and functions. Switches are often normally open and when the switch position is changed from OFF to ON, the switch contacts will close and energize a circuit, the same as when you turn on a light. Switches can also be designed to be normally closed, which de-energizes the circuit when the contacts open.



Most commonly used switches:

Transistors:

A transistor is one of the elementary components of most any electronics device. A transistor has 3 pins, base, emitter and collector, and comes in two types. PNP and NPN.

Both work the same, but PNP has reversed polarities, and is a little bit trickier to use than NPN. The way the transistor works is very much the same as a relay. When power passes through two pins, power is allowed through the two others.

A transistor works by changing its resistance between the pins collector (power going in), and emitter (power going out), depending on how much current flows through the base to the emitter. Unfortunately, all transistor's base collector and emitter pins, are in different places varying from transistor to transistor, which is why you'll never find any transistor pin assignment diagrams.

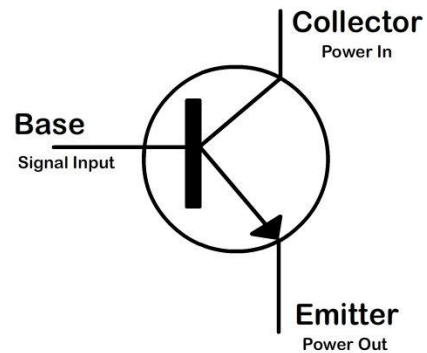

Transistors unlike relays can open up by specific amounts, which are directly proportional to the current going through the base. This proportion is the gain. For example, if a transistor had a gain of 100, then for every 1ma flowing through the base, 100ma could flow through the collector to the emitter, which technically is considered to be an amplification effect. However when you do this, a transistor tends to get rather hot, transistors operate best either when they are fully ON or fully OFF.

All transistors have a maximum input before the input starts to have no effect on the current gain, and eventually, if it gets too high, the current stops all together, which happens only when the voltage on the base is too close or the same to the voltage on the collector. When we talk about using transistors just as on/off switches, we generally operate at currents that would saturate, or fully switch on, the transistor.

Benefits:

- Time it takes to switch on is considered simultaneous or instant.
- Very small in size.

- Almost never wear-out.
- Can amplify analog signals.

Relay switches:

A relay is a device that uses an electromagnet to mechanically pull two connections together to complete a circuit, in the exact same way your finger mechanically pushes two contacts together in a toggle switch. They are used as remote control switches. The relay has two inputs (control circuit), one for the positive of our input signal and the other for the negative. When a signal passes through the input pins of the relay, current passes through the electromagnet coil which pulls the metal connector towards the magnet.

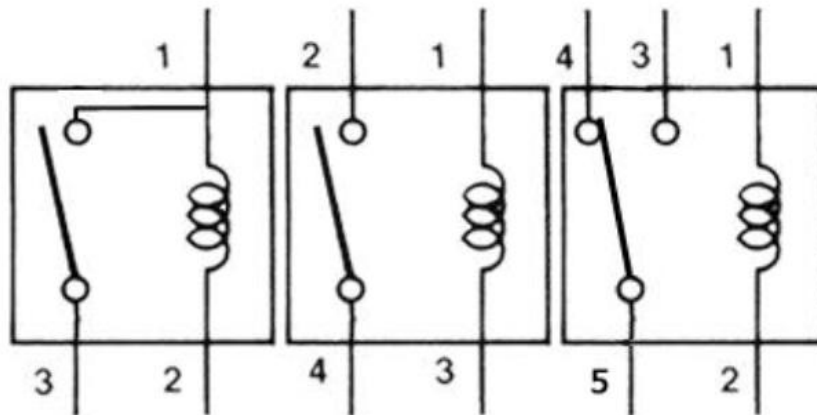

A typical 3 - PIN 4 - PIN 5 - PIN relay generally has 5 pins on it (SPDT - single pole double throw switch) These are referred to as, Input 1, Input 2, COM, N/O, N/C

Load circuit pins:

COM: is short for common ground, in most cases you connect the negative of the power you are switching to this. If your application uses the same power source, you can connect Input 2 and COM together. COM is the middle terminal, and is connected to the pin that the contact gets pulled towards.

N/C: Short for normally closed, this terminal is not connected to COM when there is no signal, but when there is a signal, the pin inside the relay is pulled down until it touches N/C, which would connect it to COM.

N/O: short for normally open, uses a small spring to make it always touching COM when the magnet is off. N/O is used in most cases to turn on the standby light, as it switches on when there is no power.

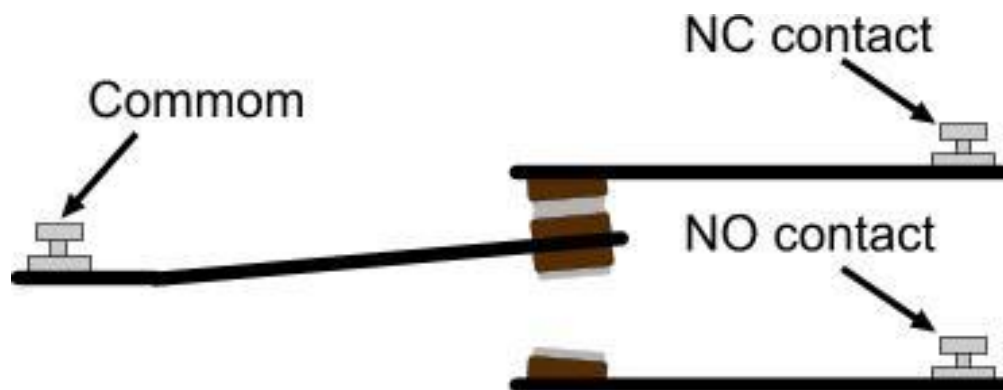

Benefits:

- Relays can work with AC and DC, while transistors are DC only.
- Relays have zero closed resistance, while transistors have a forward voltage drop that wastes a little to lots of power.
- Relays have infinite open resistance, while transistors have a leakage that can affect attached electronics.
- Relays offer complete isolation between the activating circuit and the load.

We chose to use an available multiple relay switch board (5 pin relays – ULN 2803AG IC) in this project since the accompanied delay in switching is not of essence, we don't need to vary switched current and relay has its previously mentioned benefits.

The board requires 12V to operate, but features low current draw, and has 4 pins per relay switch to control it, one for control, common, N/C (connected when switch was on) and N/O (connected when switch is off).

To use a 5V input from arduino to activate a single 5 pin relay, we can use a transistor to add gain to the 5V such that it will be enough to activate the switch. We will also use a clamp diode to protect the relay from inverse current.

The fig. on the right is an example of the required connection but using a 4-pin relay.

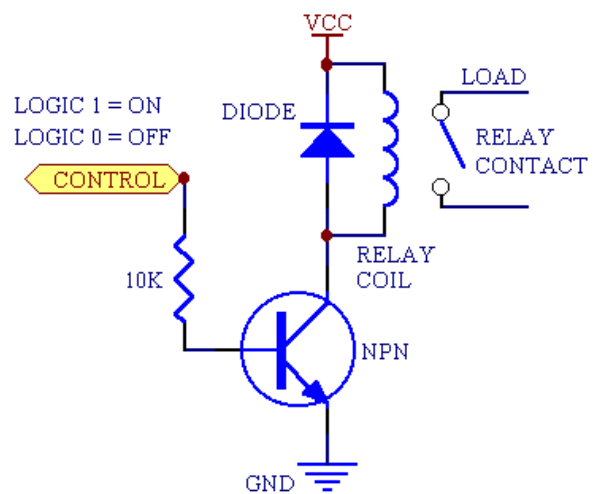

The control and Vcc will be connected to 5V.

In this project we will use the relay to perform the following switches:

1. Switching between the 12V Power Supply (representing the governmental electricity source) and a 12V battery.
2. Switching between the 5V Power Supply (representing the governmental electricity source) and a 5V battery.
3. Switching between charging (Day) and discharging (Night) the battery.

RTC (Real Time Clock) module:

A real-time clock (RTC) is a computer clock (most often in the form of an integrated circuit) that keeps track of the current time. This should not be confused with hardware clocks which are only signals that govern digital electronics, and do not count time in human units. The RTC module keeps accurate time for years using a tiny

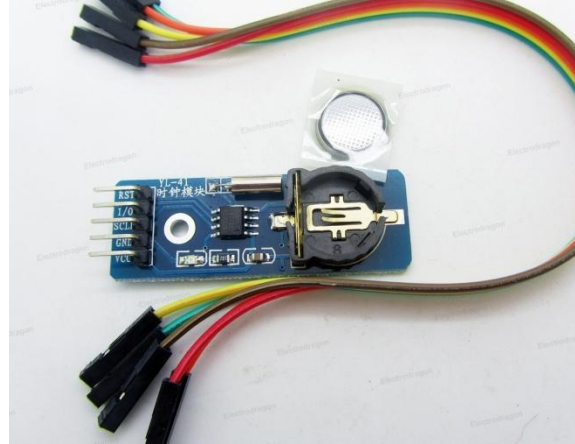

coin-cell, and is very simple to connect to the Arduino board. The module uses the Arduino analog pins A4 and A5 for "I2C" serial communications with the sketch. No other pins on the Arduino are used by the module other than power and GND, so they are all available for connection to other devices in your projects. A driver library allows a program to easily set or read the time and date.

Module Pin connections:

VCC: Connect the 5V or 3.3V from your Arduino or circuit here to power the module

GND: Connect this to your Arduino or board's GND pin

SDA: This is the I2C bus data pin, connect to your Arduino's A4 pin

SCL: This is the I2C bus clock pin, connect to your Arduino's A5 pin

RTCs often have an alternate source of power, so they can continue to keep time while the primary source of power is off or unavailable, but since we will have the Arduino always running we can supply the RTC through the Arduino.

Although keeping time can be done without an RTC, using one has benefits:

- Low power consumption
- Frees the main system for time-critical tasks
- Sometimes more accurate than other methods

We decided to use RTC as a backup for LDR motor control, and to enhance control accuracy of the LED(s) in case of cloudy days. We can decide the motor angle through knowing the current time, and we can have a condition that the time obtained through RTC be night-time along with the threshold condition of LDR for the LED's to emit light.

In order to use RTC, we use the "wire" (allows you to communicate with I2C devices) library as well as a downloaded specified library called "DS1307".

In the setup function of the code we must write:

```
{Serial.begin(9600);  
// Sets the data rate in bits per second (baud) for serial data transmission  
  
Wire.begin();  
  
// Initiates the Wire library and joins the I2C bus as a master or slave  
  
clock.begin();  
  
// Initiates RTC library
```

Functional Overview

```
hour();      // The hour now (0-23)

minute();   // The minute now (0-59)

second();   // The second now (0-59)

day();      // The day now (1-31)

weekday();  // Day of the week, Sunday is day 1

month();    // The month now (1-12)

year();     // The full four digit year: (2009, 2010 etc)

setClock(yyyy, mm, dd, hour, minu, sec); //sets RTC time and date

clock.getTime(); //get the time from the RTC
```

Further Inquiry on the RTC:-

Furthermore, the RTC is a device which counts the time in real manner with the help of accurate crystal. The RTC used here is DS1302. It is an 8-pin RTC with simple 3-wire interface. It counts seconds, minutes, hours, date of the month, month, day of the week, and year with leap-year compensation valid up to 2100.

It is interfaced to the Arduino via a simple serial interface and programmed according to our requirements. The time can be accessed & modified using the microcontroller.

The DS1302 trickle-charge timekeeping chip contains a real-time clock/calendar and 31 bytes of static RAM. It communicates with a microprocessor via a simple serial interface. The Real Time Clock / Calendar provides Seconds, Minutes, Hours, Day, Date, Month, and Year information. Only three wires are required to communicate with the Real Time Clock / RAM: CE, I/O (data line), and SCLK (serial clock). Data can be transferred to and from the clock/RAM 1 byte at a time or in a burst of up to 31 bytes. The DS1302 is designed to operate on very low power and retain data and clock information on less than $1\mu\text{W}$. The DS1302 Real Time Clock has dual power pins, one for primary and another for backup. In this example the Primary power will be provided by the Arduino, and the back up by a CR2032 battery.

The 31 bytes of RAM is formatted as shown in the table below. Notice that the numeric positions have their own bits to fill. Specifically the 0-9 value of the 'ones' place have 4 bits, and the 0-9 value of the 'tens' place has 3 bits for the byte filled with the seconds value. These values are combined to create the entire byte.



Here you can see the wiring diagram for the DS1302 Real Time Clock. Vcc2 is set to accept the primary power, this is typically 3.3V, but can use 5V. It is recommended that more than 7V is applied, as this can damage the unit. VCC1 is set aside for the backup power, provided by the 3.3V CR2032 Coin Battery. The quartz crystal is placed between the #2 and #3 pins. Pin #5-7 are set aside for the data communication between the module and the micro controller. In previous versions of the module, and DS1302, there is a pin labeled as 'RESET', this is the same pin as "CE". The pins serve the same function, simply relabeled in this version. The library will allow for the communication pins to be connected to any type of pin on the Arduino or Versilino boards. This means that they can be connected to the PWM, DIGITAL, COMMUNICATION, or ANALOG pins and work. Below you can see the wiring diagram for connecting to the Arduino Mega 2560.

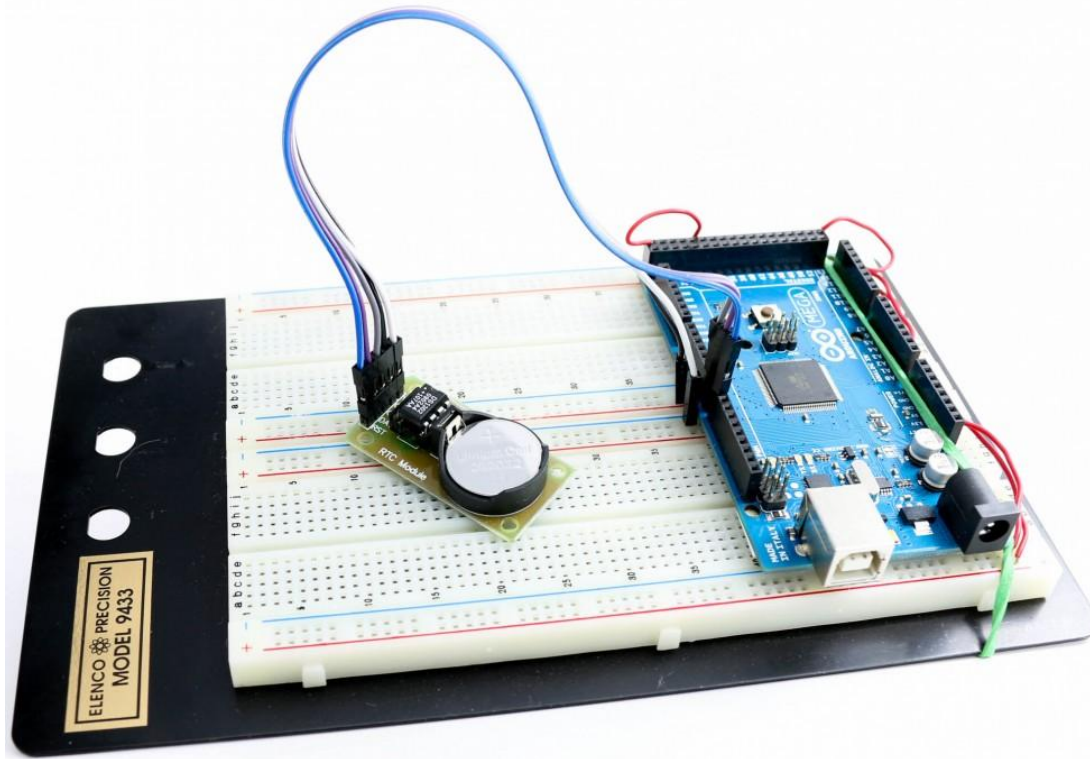

If you choose to run the library on the Versalino it would probably be easiest to add an `#include` , and change the pin calls to `virtuabotixRTCmyRTC(BUSA.D1, BUSA.P1, BUSA.D2);` instead of `virtuabotixRTCmyRTC(6, 7, 8);`

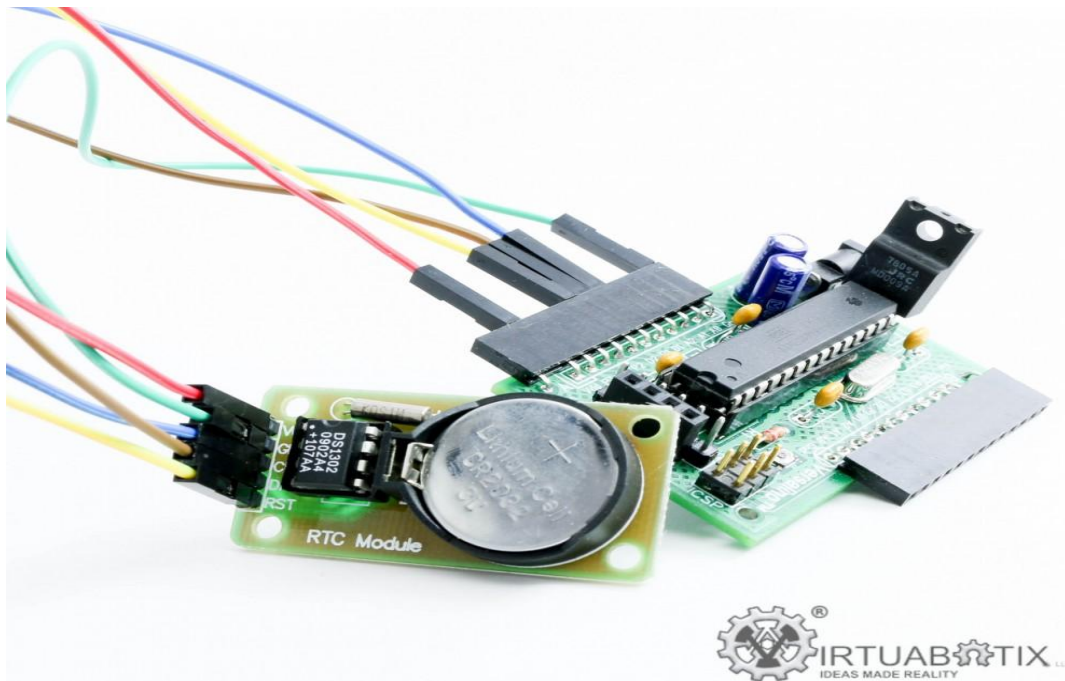

The library provided by Virtuabotix, LLC provides users with the ability to use the RTC Module in a plug and play fashion. Once the library is imported, simply create the object and define the pins needed for communication, and set the time. At that point all functions within the library are active. While these are primarily background functions that keep the time current, the single function that the user needs is `updateTime()`. This function allows for the user to access any of the elements within the time. This library comes with two examples: one that will simply print the current date and time, and one that will verify that the RTC is tracking time changes by illuminating LEDs to verify a good, or bad, RTC.

Note:Users should be reminded that the time to process code between printout statements can accumulate over time. This is especially noticed when printing out the data at different points within the main program. When code is executed this way it appears that the time is drifting, be

assured that it is most likely not drifting, just the time between calls adding up over time.

```
#include
<virtuabotixRTC.h>
//|
02
03          // Creation of the Real Time Clock Object
04          //SCLK -> 6, I/O -> 7, CE -> 8
05          virtuabotixRTCmyRTC(6, 7, 8);
06
07          void setup() {
08          Serial.begin(9600);
09
10          // Set the current date, and time in the following
          format:
11          // seconds, minutes, hours, day of the week, day of the
          month, month, year
12          myRTC.setDS1302Time(00, 59, 23, 6, 10, 1, 2014);
13          }
14
15
16          void loop() {
```

```
17 // This allows for the update of variables for time or
    accessing the individual elements.
18 myRTC.updateTime();
19
20 // Start printing elements as individuals
21 Serial.print("Current Date / Time: ");
22 Serial.print(myRTC.dayofmonth);
23 Serial.print("/");
24 Serial.print(myRTC.month);
25 Serial.print("/");
26 Serial.print(myRTC.year);
27 Serial.print(" ");
28 Serial.print(myRTC.hours);
29 Serial.print(":");
30 Serial.print(myRTC.minutes);
31 Serial.print(":");
32 Serial.println(myRTC.seconds);
33
34 // Delay so the program doesn't print non-stop
35 delay( 5000);
36 }
```

External Power Source:

The Arduino requires a power source to function. This will be a power supply.

A 12 V adapter was used for deriving power from the AC mains. The servo motor works with 6V dc power supply and the controller, sensors, RTC and the LCD work with 5V DC power.



Motion

Detection Sensors

There are a number of different motion sensor technologies out there including Active Infrared (AIRs), Passive Infrared (PIRs), Microwave motion sensors and Ultrasonic motion sensors.

AIR (Active Infrared): They mainly have two implementations. Proximity sensors, used in the automatic trash bin, automatic water taps, and different others; and motion sensors. In AIR-based motion sensors, an IR emitter sends a beam of IR which will be received by an IR receiver, when the beam is interrupted, a motion is detected. Due to the way they're implemented (monitoring a specific scope) they're less prone to false positives. Their main disadvantage is detectability, they can be easily "seen" using a regular camera (your phone's camera works) or any IR detection mechanism, after that they can be easily avoided. In some cases, they might be impossible to avoid (they're monitoring the only door to a room), the adversary can detect the source of the beam and find the receiver, then emit a beam of their own. Some AIR-based motion sensors emit IR in a pattern of a certain frequency to make it difficult to replicate, but of course the adversary can learn that pattern and replay it to the receiver.

Optic-based: Basically a camera watches an area and it's recording at a certain frame rate, each frame (or several frames) are analyzed by an algorithm that can detect the difference between the last frames. If something is different, a motion is detected. They can be overcome with

utilizing shadows and exploiting backgrounds with a solid color. That, of course, can be solved with using thermal imaging and/or installation-specific measures (eliminating shadows with controlled light). There's a lot of cutting-edge research in this area, especially in video amplification. Researchers at MIT were able to detect a person's heart rate from a normal video footage.

Piezoelectric: I personally haven't seen or used those. They basically use the piezoelectric effect (mechanical forces having an electrical effect on some materials). They can be mounted on the floor in order to detect pressure and vibration. They're vulnerable to Flying Nimbus attacks.

Ultrasonic: They work by emitting an ultrasonic "beam". They work the same way as a sonar. They can be defeated by wearing an anechoic suit.

PIR sensor :

The main electronic component we will use that allows us to pick up this detection is the PIR motion sensor. The PIR motion sensor is a sensor which detects movement through picking up infrared radiation. Being that a person emits infrared radiation, the detector is able to detect this and react according to the how the circuit is designed to react. The sensor can also pick up the movement of inanimate objects as well, such a rolling ball, because as those objects move, friction acts on them, generating heat. This

heat emits infrared radiation, which the PIR sensors may be able to detect if great enough.

Motion Sensor Light Circuit with an Arduino



In this project, we will go over how to build a motion sensor light circuit with an arduino. A motion sensor light circuit is a circuit in which a light turns on when motion is detected.

With a PIR motion sensor integrated with an arduino, we can detect movement and program the arduino to turn a light on for a certain period of time once this motion is detected.

For example, once motion is detected, we will turn on the light attached to the output of the PIR sensor for 1 minute. This is how most commercial motion sensor lights work. When motion is detected, the light will turn on for about 1 or 2 minutes. If the light turned on and stayed on for only the

second that motion is detected, this wouldn't be very useful. When motion is detected by a motion sensor light, it will stay on for at least a period of time, on average 2 minutes, so that it can provide illumination for this time if the person that triggered the sensor stays in the area. Then, after this period of time has elapsed, it will shut off. If the person continues moving in the vicinity of the motion sensor, it will then be triggered again and stay on for 2 minutes again. This cycle will continue as long as needed. Again, this is how most commercial motion sensor lights work.

You can decide how long you want the light to stay on once detected for your circuit. You will see how to do this in the code you will write and upload to the arduino board.

Parts Needed

- Arduino Board
- PIR motion sensor
- LED
- USB with type A and B connectors

The PIR motion sensor is a 3-pin device. the pinout of this Device:

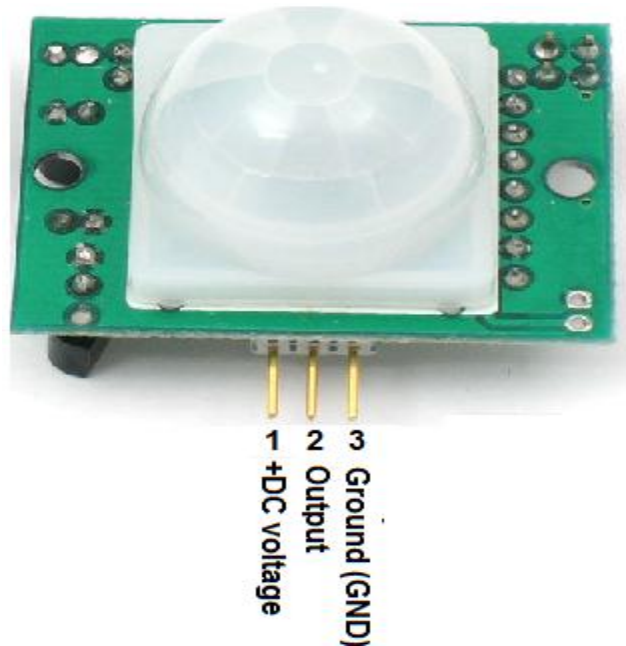

Pin 1 is the pin which receives the positive DC voltage. The PIR motion sensor needs between 5V-9VDC of power for operation. In our case, we will use about 6V of power. This can be obtained from switching a DC power supply to 6V or using 4 'AA' batteries connected in series. We will then feed this voltage into pin 1 of the PIR module.

Pin 2 is the negative DC voltage or ground pin of the device. We connect the negative terminal of the power source to this pin, for a return path.

Pin 3 is the Output pin of the PIR module. This is where the output of the PIR will leave from. When motion is detected by the PIR, its output will go high to 3V. When no motion is detected, its output low and it gives off practically no voltage. When high you can see then how it can power the LED will we attach to this pin.

This sensor has a sensitivity range up to 20 feet (6 meters) and a $110^\circ \times 70^\circ$ detection range, making it a wide lens detection sensor. This means it can measure 110° vertically (from top to bottom) and 70° horizontally (from left to right). The best way to check its sensitivity is when the circuit is built, try moving around through all of its angles. See at which angles it can detect your movement and at which angles it is not able to detect your movement, meaning your out of its angle scope. A lot of it is trial and error and experimenting. Once you know where it can and cannot detect, you can place it in an optimal place where it can detect in areas where you want it to.

Besides this sensor, we need an LED, which we will light when motion is detected.

You can use any arduino board. You will need a USB with a type A connector at one end and a type B connector at the other. The type A side connects to the computer you will be using and the type B plugs into the arduino USB slot. This way, we can program and upload software for the arduino board to follow.

Arduino Motion Sensor Light Circuit

The arduino motion sensor light circuit we will build is shown below:

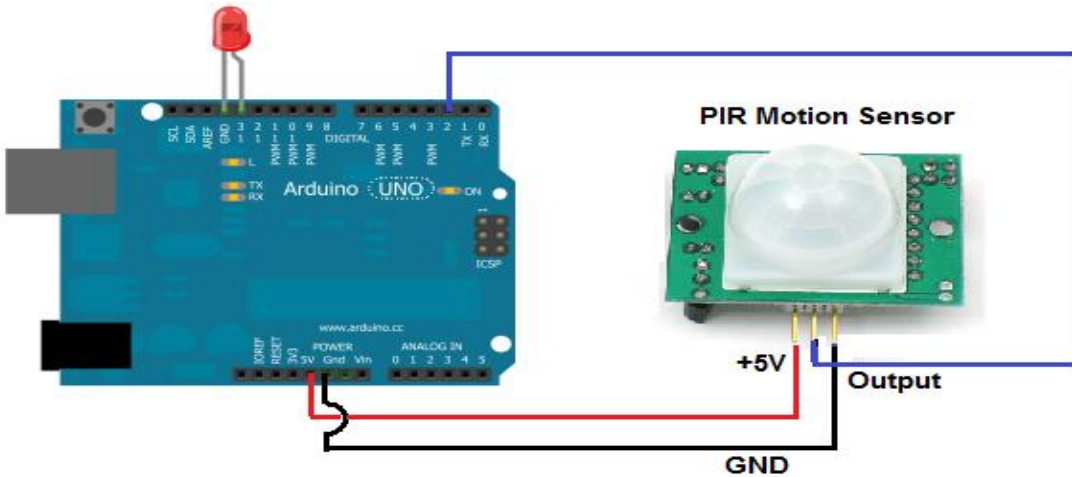

The schematic diagram of this circuit is:

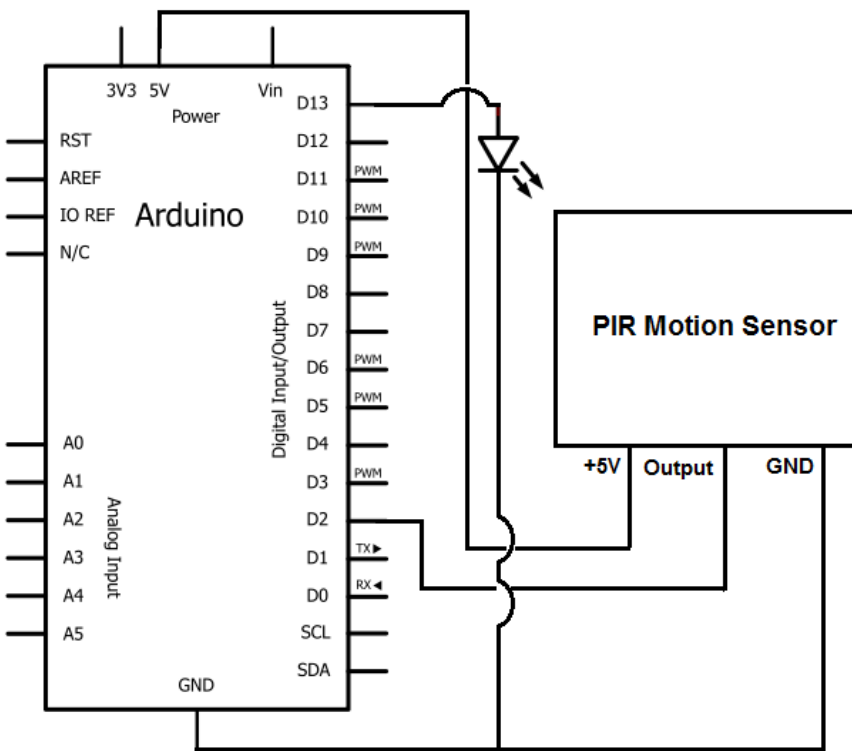

Pin 1 of the motion sensor connects to the 5V DC voltage terminal of the arduino. Pin 3 connects to the ground (GND) pin of the arduino. Pin 2, the output, connects to the digital pin D3.

With this connection, pins 1 and 3 are powered with 5V by the arduino, so it is through these pin connections that the PIR motion sensor gets the 5V that it needs to power on and operate.

And it is through pin 2 that the arduino receives output from the motion sensor. When the motion detector does not detect any motion, the output is LOW and the arduino receives no voltage signal. When the sensor detects motion, the output is HIGH and the arduino receives a voltage signal, which can then trigger another device to turn on, such as an LED we will use for this circuit.

The LED we will light connects pin 13 and ground of the board. The anode connects to pin 13 and the cathode connects to ground. No external resistor is necessary to limit current to the LED, because pin 13 already has built-in resistance to limit current flow.

Program for Arduino Motion Sensor Light Circuit

After we connect the USB from the arduino to the computer, we are ready to write the code that the arduino board will need uploaded to it so that it knows to light the LED when motion is detected.

The following code, or sketch, will light the LED on pin 13 when the sensor detects motion:

```
//code for motion sensor circuit
constintledPin= 13;
constintinputPin= 2;
```

```
void setup(){
  pinMode(ledPin, OUTPUT);
  pinMode(inputPin, INPUT);
}

void loop(){
  int value= digitalRead(inputPin);

  if (value == HIGH)
  {
    digitalWrite(ledPin, HIGH);
    delay(60000);
    digitalWrite(ledPin, LOW);
  }
  else
  {
    digitalWrite(ledPin, LOW);
  }
}
```

The first block of code chooses the pin for the LED, which is pin 13. The second line chooses the pin for the input pin, which represents the PIR sensor, pin 2.

The second block of code declares the LED as output and the input pin as input.

The third block of code reads the sensor value of the sensor and assigns it to the integer value.

The fourth block of code determines whether the sensor pin is HIGH or LOW. If it is HIGH, then the motion sensor has detected motion. If it is low,

the sensor has not detected any motion. If the value is HIGH, it turns the LED on, signaling that motion has, in fact, been detected. The LED stays on for 60000ms, which is equal to 1 minute. After this period of 1 minute has elapsed, the LED then turns LOW (or off). Again, you can modify this code so that the LED stays on for 5 seconds after motion has been detected or any time period. All this can be done by changing the value given to the delay() function. 5 seconds would be 5000ms. 2 minute would be 120000ms. 30 seconds would be 30000ms. Customize the code to suit your circuit's needs.

Adjustable Infrared Sensor

In this project we are using Adjustable Infrared Sensor Switch 3-80cm

The Adjustable Infrared Sensor Switch is a set of transmitter and receiver in one of the photoelectric switch sensor. The detection distance can be adjusted according to the demand. The sensor has a detection range of 3cm-80cm. The switching signal output differs in accordance to the obstacles. It remains high when no obstacles and remains low when there are obstacles.

It is small, easy to use/assemble, inexpensive. Useful for robot, interactive media, industrial assembly line, etc.

Specification

- Power supply: 5V

- Current:100mA
- Range:3-80cm adjustable
- Red: +5V; Yellow:Signal;Green:GND
 - Type :DC 3 Wire NPN-NO (Normal Open)
 - Sensory distance regulator and output indicator light on product back

Control signal level:

- High : $2.3V \leq V_{in} \leq 5V$
- Low : $-0.3V \leq V_{in} \leq 1.5V$

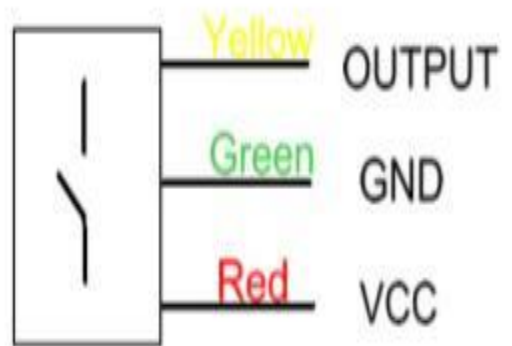

The transmitter port of Arduino Bi-Directional Infrared Switch is used to transmit the signal.



he transmitter module have two interfaces port :

The green interface connect with GND;

The red interface connect with 5V VCC .

So we can use the 5V power supply to power this module.

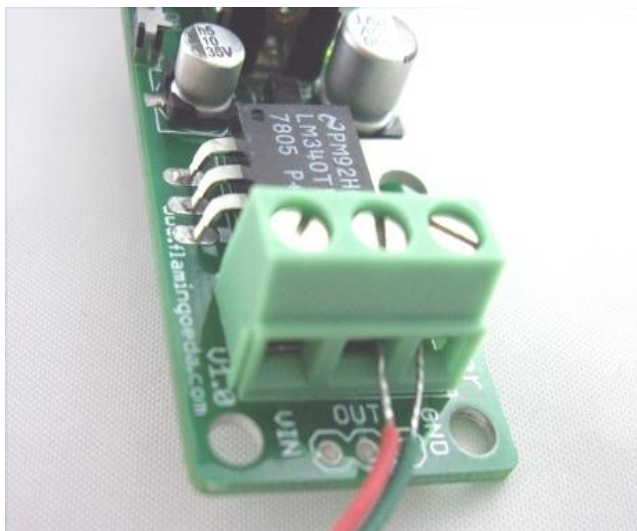

The receiver module have three interfaces port :

The green interface connect with GND ;

The red interface connect with 5V VCC ;

The yellow interface connect with signal .

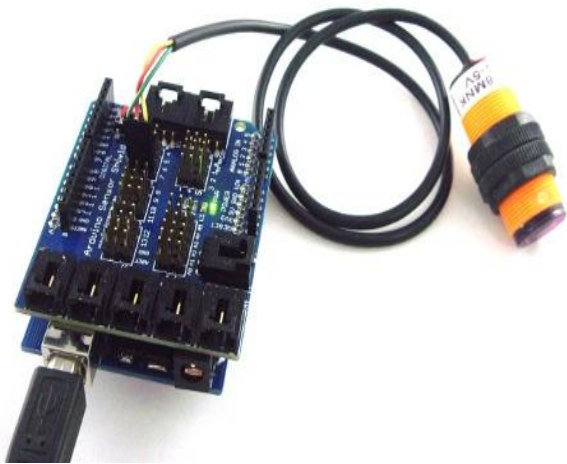

Through the signal reading from infrared receiver module is different ,
Arduino will turn on or off the indication LED of No.13 I/O pin of Arduino.

Test Code :

```
int ledPin = 13;
int switchPin = 7;
int value = 0;

void setup() {
  pinMode(switchPin, INPUT);
  pinMode(ledPin, OUTPUT);
  Serial.begin(9600);
}

void loop() {
  value = digitalRead(switchPin);
  if (HIGH == value) {
    digitalWrite(ledPin, HIGH);
  } else {
    digitalWrite(ledPin, LOW);
  }
  //delay(100);
}
```

Light-emitting diode (LED)



Is a two-lead semiconductor light source, It resembles a basic pn-junction diode, which emits light when activated. When a fitting voltage is applied to the leads, electrons are able to recombine with electron

holes within the device, releasing energy in the form of photons. This effect is called electroluminescence, and the color of the light (corresponding to the energy of the photon) is determined by the energy band gap of the semiconductor.

An LED is often small in area (less than 1 mm²), and integrated optical components may be used to shape its radiation pattern.

Hardware Required:

- Arduino Board
- LCD Screen (compatible with Hitachi HD44780 driver)
- pin headers to solder to the LCD display pins
- 10k Potentiometer
- breadboard
- hook-up wire

To wire your LCD screen to your Arduino, connect the following pins:

- LCD RS pin to digital pin 12
- LCD Enable pin to digital pin 11
- LCD D4 pin to digital pin 5
- LCD D5 pin to digital pin 4
- LCD D6 pin to digital pin 3
- LCD D7 pin to digital pin 2
-

Additionally, wire a 10K pot to +5V and GND, with it's wiper (output) to LCD screens VO pin (pin3).

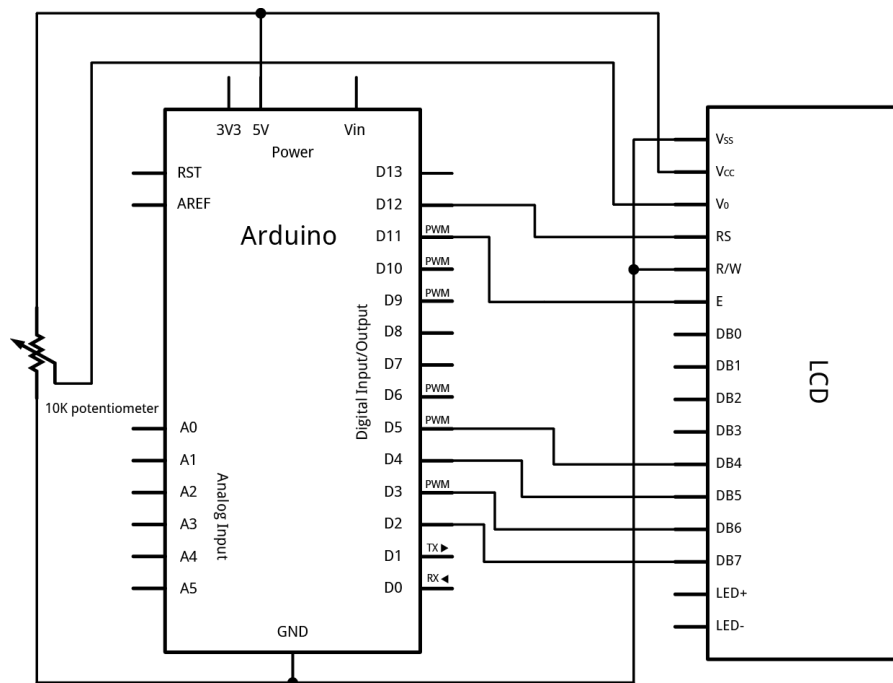

The circuit:

- * LCD RS pin to digital pin 12
- * LCD Enable pin to digital pin 11
- * LCD D4 pin to digital pin 5
- * LCD D5 pin to digital pin 4
- * LCD D6 pin to digital pin 3
- * LCD D7 pin to digital pin 2
- * LCD R/W pin to ground
- * 10K resistor:
- * ends to +5V and ground
- * wiper to LCD VO pin (pin 3)

Example code

Code

/*

LiquidCrystal Library - Hello World

Demonstrates the use a 16x2 LCD display. The LiquidCrystal library works with all LCD displays that are compatible with the Hitachi HD44780 driver. There are many of them out there, and you can usually tell them by the 16-pin interface.

This sketch prints "Hello World!" to the LCD and shows the time.

The circuit:

- * LCD RS pin to digital pin 12*
- * LCD Enable pin to digital pin 11*
- * LCD D4 pin to digital pin 5*
- * LCD D5 pin to digital pin 4*
- * LCD D6 pin to digital pin 3*
- * LCD D7 pin to digital pin 2*
- * LCD R/W pin to ground*
- * 10K resistor:*
 - * ends to +5V and ground*
 - * wiper to LCD VO pin (pin 3)*

Library originally added 18 Apr 2008

by David A. Mellis

library modified 5 Jul 2009

by Limor Fried (<http://www.ladyada.net>)

example added 9 Jul 2009

by Tom Igoe

modified 22 Nov 2010

by Tom Igoe

This example code is in the public domain.

<http://www.arduino.cc/en/Tutorial/LiquidCrystal>

**/*

// include the library code:

`#include <LiquidCrystal.h>`

// initialize the library with the numbers of the interface pins

`LiquidCrystallcd(12, 11, 5, 4, 3, 2);`

`void setup() {`

// set up the LCD's number of columns and rows:

`lcd.begin(16, 2);`

// Print a message to the LCD.

`lcd.print("hello, world!");`

`}`

`void loop() {`

// set the cursor to column 0, line 1

// (note: line 1 is the second row, since counting begins with 0):

`lcd.setCursor(0, 1);`

// print the number of seconds since reset:

`lcd.print(millis()/1000);`

`}`

Servo Motors

Unlike dc motors, with servo motors you can position the motor shaft at a specific position (angle) using control signal. The motor shaft will hold at this position as long as the control signal not changed. This is very useful for controlling robot arms, unmanned airplanes control surface or any object that you want it to move at certain angle and stay at its new position.

Servo motors may be classified according to size or torque that it can withstand into mini, standard and giant servos. Usually mini and standard size servo motors can be powered by Arduino directly with no need to external power supply or driver.

Usually servo motors come with arms (metals or plastic) that are connected to the object required to move (see figure below to the right).



How Does the Servo Motor Works?

Your servo has 3 wires:

Black wire: GND (ground)

RED wire: +5v

Colored wire: control signal

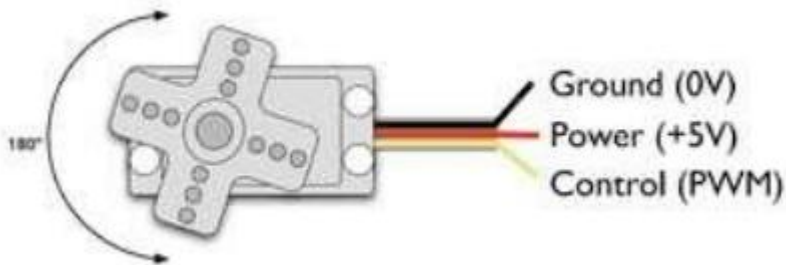

The third pin accepts the control signal which is a pulse-width modulation (PWM) signal. It can be easily produced by all micro-controllers and Arduino board. This accepts the signal from your controller that tells it what angle to turn to. The control signal is fairly simple compared to that of a stepper motor. It is just a pulse of varying lengths. The length of the pulse corresponds to the angle the motor turns to.

The pulse width sent to servo ranges as follows:

Minimum: 1 millisecond ---> Corresponds to 0 rotation angle.

Maximum: 2 milliseconds ---> Corresponds to 180 rotation angle.

Any length of pulse in between will rotate the servo shaft to its corresponding angle. For example, 1.5 ms pulse corresponds to rotation angle of 90 degree.

This is will explained in figure below.

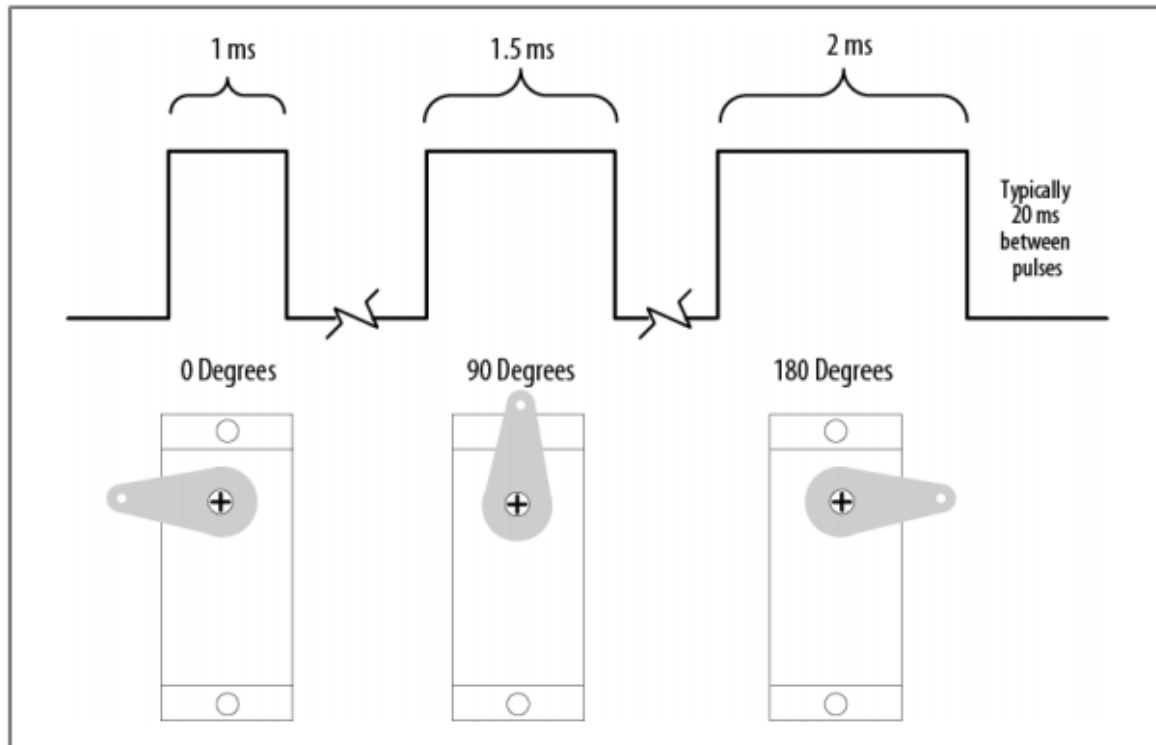

Inside the Servo Motor

Did ever wonder how the servo motors looks from inside? Have a look at the corresponding picture. A servo motor was taken apart to show the internal parts.

You can see a regular dc motor connected to a gear box and a potentiometer that give the feedback for angle position.

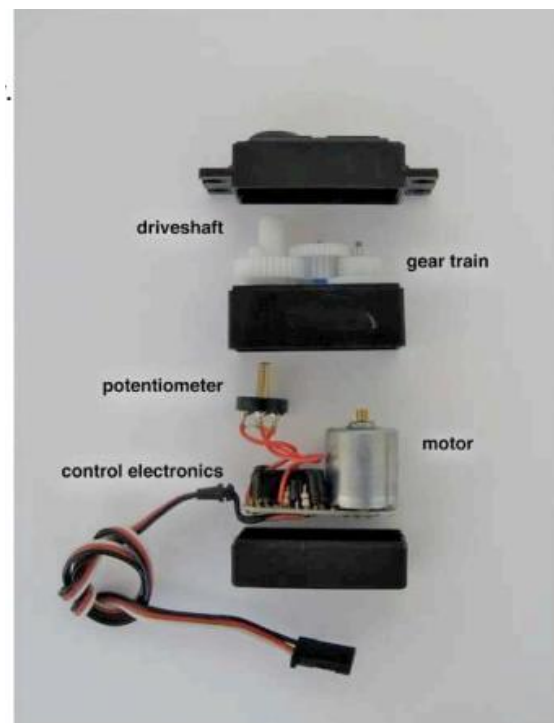

Motor Control Using Arduino

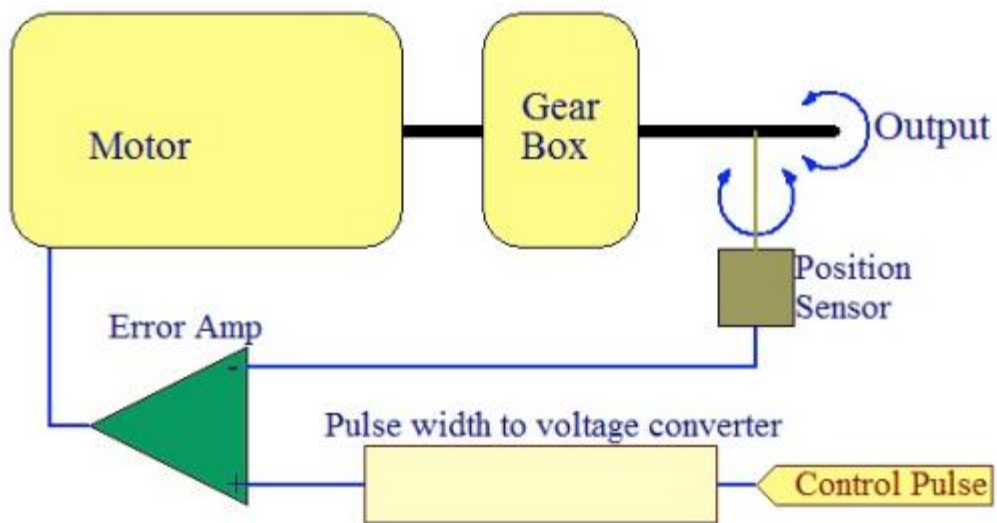

Standard servo motor control using Arduino is extremely easy. This is because the Arduino software comes with a sample servo sketch and servo library that will get you up and running quickly

1. Connect the black wire from the servo to the Gnd pin on the Arduino
2. Connect the red wire from the servo to the +5V pin on the Arduino
3. Connect the third wire (usually orange or yellow) from the servo to a digital pin on the Arduino

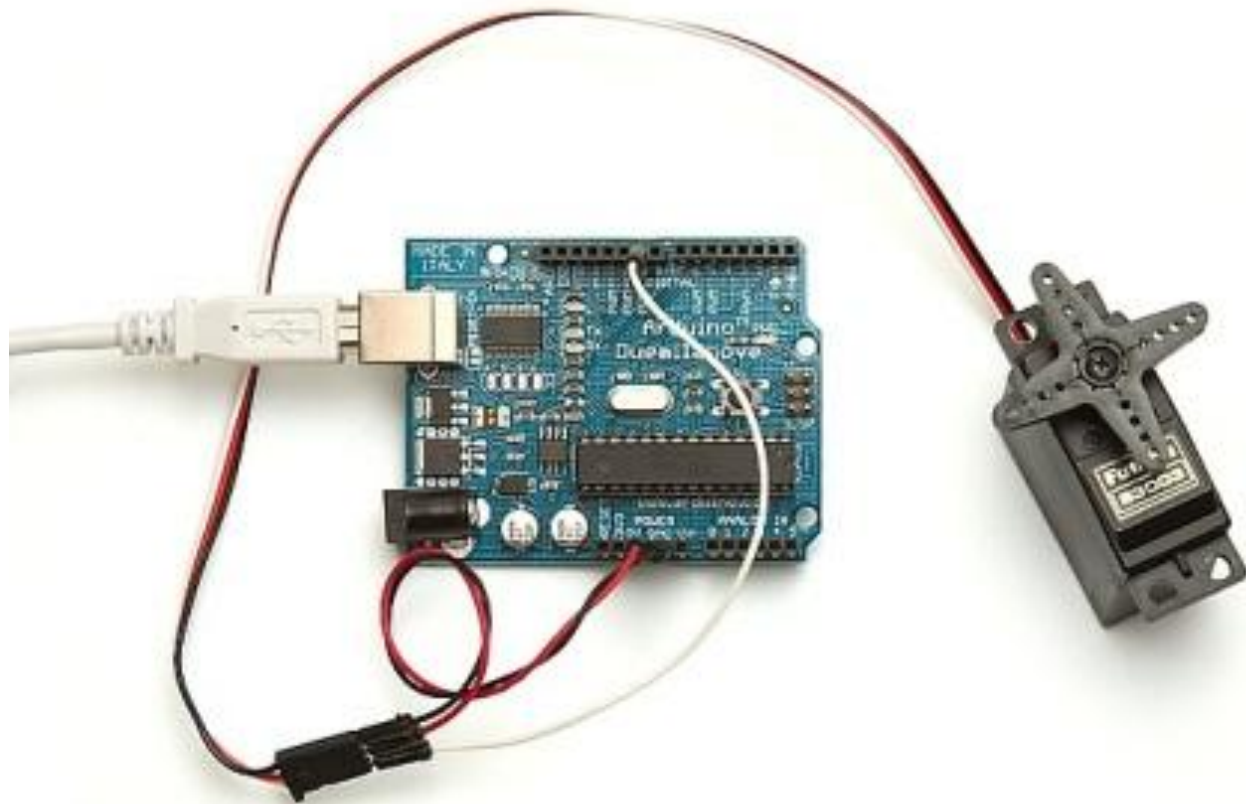
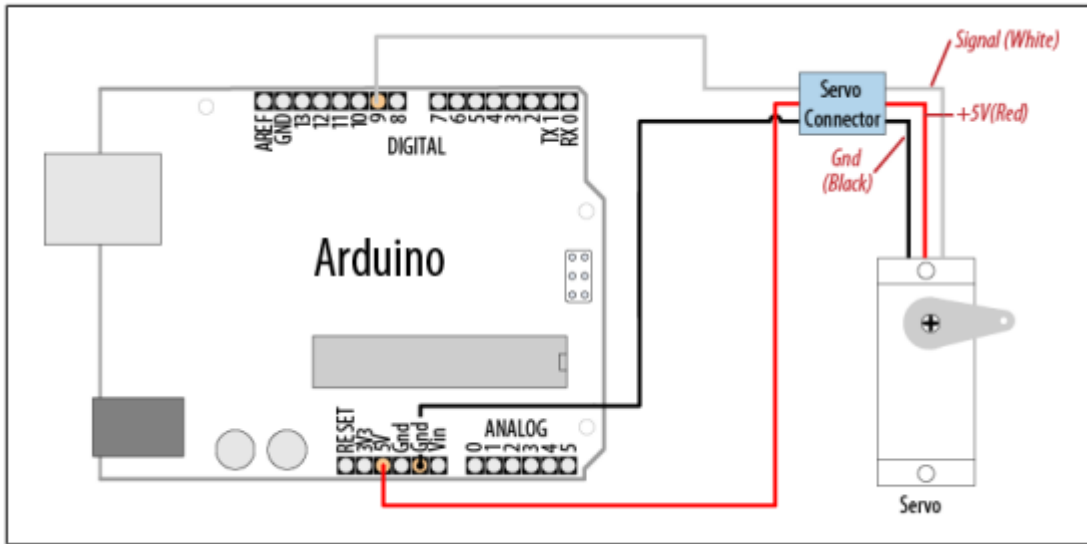

Important Notes:

1- It is not a good idea to connect a motor of any kind directly to the Arduino because it usually requires more power than the board can provide.

2- In our example, the servo is being used to demonstrate code and is not encountering any resistance. Note that you should use a standard or small size if you are uncertain, check the servo's no load current rating (it should usually be under 150mA).

3-You may need an external source of 5 or 6 volts when connecting multiple servos. Four AA cells work well if you want to use battery power. Remember that you must connect the ground of the external power source to Arduino ground.

Here is the example Sweep sketch distributed with Arduino:

```
#include <Servo.h>

Servo myservo; // create servo object to control a servo

int angle = 0; // variable to store the servo position

Void setup() {

264
```

!! Chapter 8: Physical Output

}

myservo.attach(9); // attaches the servo on pin 10 to the servo object

Void loop() {}

For(angle = 0; angle < 180; angle += 1) // goes from 0 degrees to 180 degrees

{

myservo.write(angle); delay(20);

// in steps of 1 degree // tell servo to go to position in variable 'angle' //
waits 20ms between servo commands

}

For(angle = 180; angle >= 1; angle -= 1) // goes from 180 degrees to 0 degrees

{

}

myservo.write(pos); delay(20);

// tell servo to go to position in variable 'pos' // waits 20ms between servo
commands

\

Component Structure

Software Component:

The main software component of the device is an Arduino microcontroller, which will be programmed to distinguish and compare light intensities from the photoresistors. The determined lowest resistance indicates the direction of the light source with the greatest intensity. The Arduino will signal the servo motors to move to the corresponding direction based on the photoresistor with the lowest resistance. This comparison will continue recursively until all photoresistors measure the same resistance.

The Arduino Mega uses Arduino programming language, which is implemented in C/C++. This is beneficial as each member of the team has had training in a C coding environment. Control structures include familiar loops such as: *for*, *while*, *do-while*, etc. Data types include: *void*, *boolean*, *char*, *int*, etc.

Three wires are typically attached to the servomotors, which connect to power, ground, and a signal. The power wire will connect to a 5V source while the signal and ground wires will connect to the programmed Arduino microcontroller. The I/O pins of the Arduino have a current limitation of 40.0mA, and the servo motor will have a maximum output voltage of 5V.



Chapter 6:

Future

Enhancement

&UPS System

Enhancements

-Designing an aluminum frame

That is light enough to be oriented by the servo motors.

-Using LabView,

Which is a highly productive development environment for creating custom applications that interact with real-world data or signals in fields such as science and engineering.

The net result of using a tool such as LabVIEW is that higher quality projects can be completed in less time with fewer people involved.

So productivity is the key benefit, but that is a broad and general statement. To understand what this really means, consider the reasons that have attracted engineers and scientists to the product since 1986. At the end of the day, engineers and scientists have a job to do – they have to get something done, they have to show the results of what they did, and they need tools that help them do that. Across different industries, the tools and components they need to succeed vary widely, and it can be a daunting challenge to find and use all these disparate items together. LabVIEW is unique because it makes this wide variety of tools available in a single environment, ensuring that compatibility is as simple as drawing wires between functions.

1. What Makes Up LabVIEW?

LabVIEW itself is a software development environment that contains numerous components, several of which are required for any type of test, measurement, or control application.

2. Benefits of LabVIEW

As Complex As You Need It to Be One of the reasons LabVIEW makes you successful is its ability to scale to meet the needs of a given application. Picking the right software is all too often a balancing act between ease of use and learning curve on one side and power and flexibility on the other. Simple, fixed-function applications are generally easy to use and can be configured off the shelf, but they rarely meet all of the requirements for real world usage. Full-fledged programming, on the other hand, is powerful and flexible but comes at the cost of increased training and development time.

LabVIEW addresses this problem by providing several ways to accomplish similar tasks, so you can make the trade-off between simplicity and

customization yourself on a task-by-task basis.

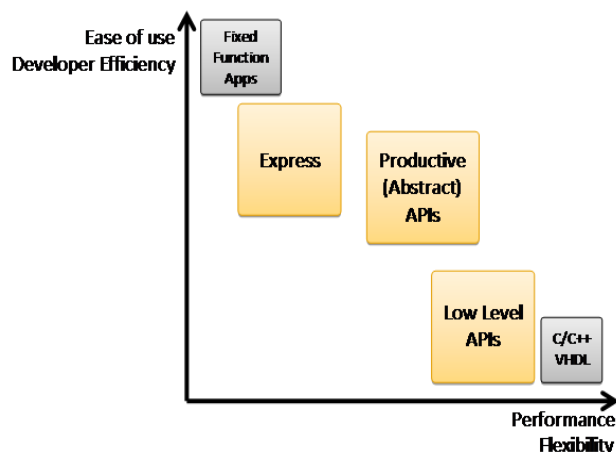
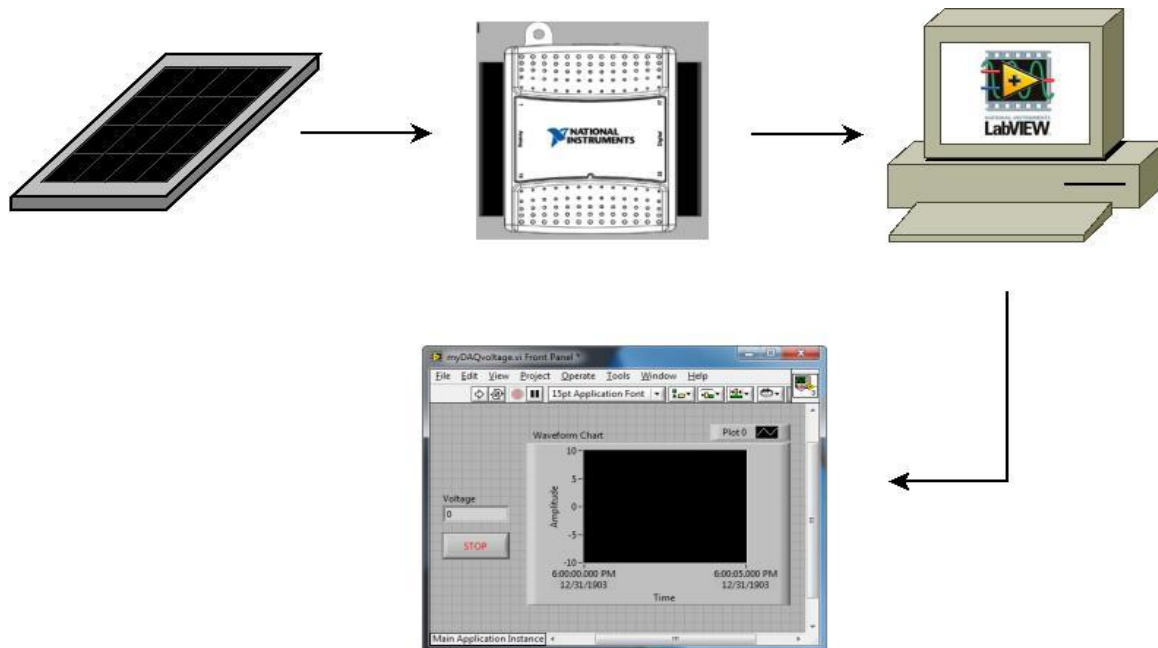

Figure. LabVIEW gives you the freedom to choose between ease of use and low-level flexibility.

By using labview we will be able to acquire data from the solar panels using theDAQmx extension on LabView as shown on Figure



we can then write a simple program to measure voltage and calculate current and power. The lab is equipped with an NI-cDAQ-9172 device that has an analog input module, NI 9215, which is capable of measuring up to 10V. In order to reduce the output voltage of the solar panel, a circuit is constructed on the breadboard to reduce the output voltage by one-tenth (see breadboard for more information). Students will measure voltage across R1, and calculate the output current using Ohm's law. The output

voltage will be measured across a R3 and multiplied by ten. Using the output current and voltage measurements, students are able to calculate the power produced by the solar panel by Ohm's Law.

So a secondary circuit will also be constructed on the breadboard to scale down the output voltage by a factor of one-tenth as shown in Figure. This method will be used to avoid measuring voltages greater than 10V using LabView.

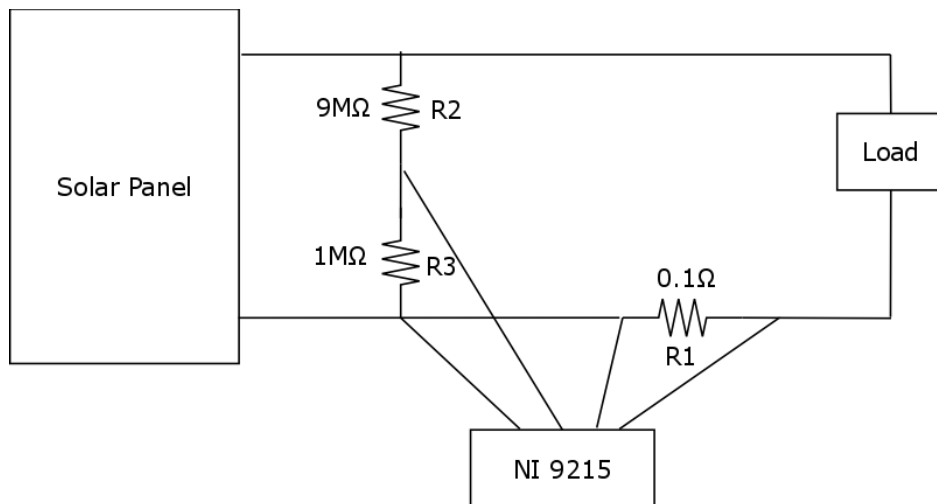

Figure: Step-down circuit and LabView Measurement

This circuit uses high precision resistors in order to avoid extra losses, which reduce the reliability of current and voltage measurements. By measuring across R3, the output voltage measured will be one-tenth of the actual voltage. Measuring the voltage across R1 can be used to calculate current. The small value of R1 functions similar to the internal resistance of a digital multimeter (DMM).

UPS

Uninterruptible power supplies

Understanding Standby Power

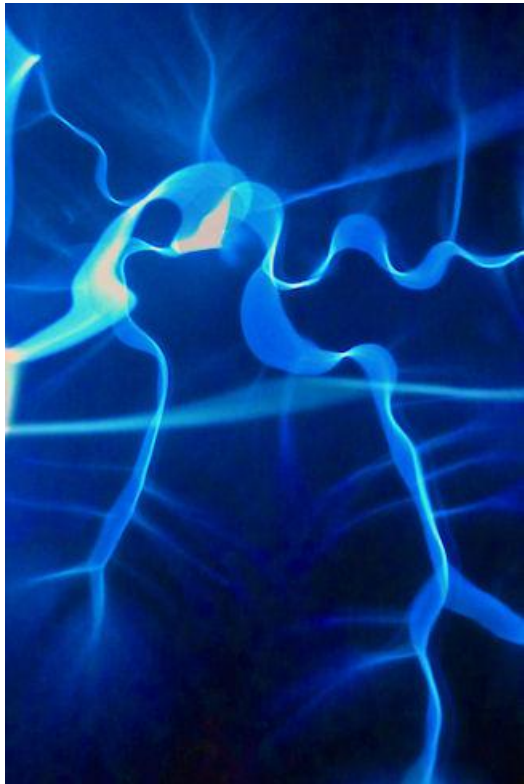

The Standby Power systems which UPS systems supply are used to support mainstream IT and communications infrastructures from the home office to the international Data Centre.

When mains power goes off, the Standby Power system will operate either from stored power usually within lead acid batteries installed within an

uninterruptible power supply ([UPS](#)) or by generated power from a generator or a combination of both as an integrated hybrid system.

What are the standby power options?

Generators can also be powered by natural gas or petrol, (or aviation fuel, if it's a gas turbine), or hydrogen in the case of Fuel Cells. Stored power can also come from NiCad batteries and flywheel systems.

In many cases, before conventional generators reach operating power, there's a time delay between mains failure and full power. As modern electronic equipment is susceptible to even momentary breaks in power a conventional generator, on its own, is often insufficient to support a computer-based system.

Because of this a 'typical' Standby Power system for a computer room incorporates both a battery-powered UPS (to bridge the time gap whilst the generator starts) and a diesel generator to provide the extended runtime that may be required.

Of course 'typical' Standby Power installations rarely exist, and we are often called upon to configure solutions where noise, or weight, or footprint, or heat output, or exhaust fumes (amongst other factors) would cause a problem.

POWER QUALITY ISSUES

A loss of power, even momentarily, can cause IT systems and sensitive equipment to crash. A UPS maintains power by switching instantaneously to batteries in the event of a power failure, or even just a dip in power (a

brownout). They also condition the power supply to reduce unwanted spikes and harmonics. They are designed to correct a variety of power problems, such as:

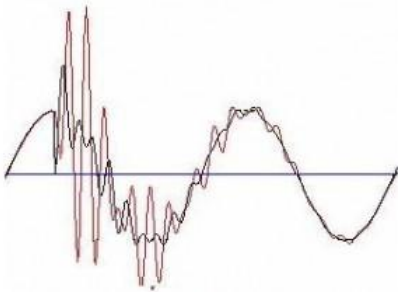

1. **Power failure** -The total loss of power. Causes electrical equipment to stop working.
2. **Sags** – Transient under voltage, can be caused by switching of heavy loads such as air conditioning or industrial machinery. Can cause IT hardware to lock-up, fail or re-boot.
3. **Surges** – Relatively short duration (from milliseconds to seconds) of high voltage. Power surges could be caused by the shut-down of a generator or other industrial motor on the local supply circuit. Will cause systems to crash, can cause components to wear and degrade over extended periods.
4. **Brownouts** -Under voltage for an extended period of time (milliseconds to seconds, minutes, hours or days). Will cause overheating in motors. Prolonged and frequent brownouts cause equipment to malfunction or not work at all.
5. **Spikes** -Very brief, but high energy bursts (lasting only a few milliseconds). Spikes are typically caused by lightning or malfunctions in the power supply. Will damage sensitive solid-state components and destroy data in digital equipment.

6. **Line noise** -Distortions superimposed on the power waveform.
Causes electro magnetic interference.
7. **Frequency variation** - Deviation from the nominal frequency. Causes motors to increase or decrease speed.
8. **Switching transient** - Instantaneous under voltage. May cause erratic behaviour in some equipment: memory loss, data error, data loss and component stress.
9. **Harmonic distortion** - Multiples of power frequency superimposed on the power waveform. Causes excess heating in wiring and fuses.

SELECTING THE RIGHT UPS



- For non-critical applications, an off-line UPS will normally resolve Power Quality Issues 1. to 3. above.
- Higher level power protection, resolving Issues 1. to 5. above, will require a line interactive UPS.
- Complete protection for mission critical systems, resolving all the Issues in 1. to 9. above, will require on-line double conversion UPS technology.

Some UPS allow a controlled shut-down of IT servers whilst others may be used in conjunction with another Standby Power source (such as additional batteries, a generator or fuel cell) to allow all or part of the facility to continue operating for very significant periods.

UPS BATTERIES



Unfortunately UPS batteries will not last indefinitely. Normal battery life expectancy is 4 years; this is dependent on frequency of use, duration of use and environmental conditions such as heat and humidity.

We advise that replacements should occur every 3 years. We also recommend that your batteries are periodically tested to ensure they are still functioning correctly.

We can supply and install all types and makes of UPS batteries, replacing them during your annual [Preventative Maintenance](#) Visit, scheduled as part of your maintenance contract, or during a Health Check. This can be done on a unit-by-unit basis or by replacing all your batteries at the same time to ease your administration and give you total peace-of-mind.

We supply replacement UPS batteries for AEC, APC, Chloride, Eaton Powerware, Emerson, Liebert, GE Digital Energy, MGE, Riello, Socomec ... and many more.

BATTERY CONFIGURATION

Sealed Valve-Regulated Lead-Acid batteries (SVRLAs) are the workhorse of almost all current UPS systems, large and small. In normal UPS use they are maintenance-free. Design life is typically either five or ten years, with some fifteen-year sizes available. Replacement is normal at least a year before the design life expires and on larger systems batteries will be checked as part of a normal service regime at least once per year. High temperatures shorten the life of all lead-acid batteries. SVRLA design life is rated at 25°C. For every five degrees above that, battery life is halved.

Many plug-in UPS have 'user-replaceable' batteries. This saves time and money when battery replacement is due. Often the cost of transporting a UPS without this feature to our workshop, plus engineer time, outweighs the cost of a new UPS, which will typically come with a two-year warranty.

Batteries are connected in series into 'strings'. The number of batteries will depend upon the DC design voltage of the system and the runtime required by the user. Multiple strings are preferable for improved reliability, as a single faulty cell within a string can render the whole string useless. For this reason, many users of larger UPS invest in battery monitoring systems, which measure battery parameters continuously, enabling our engineers to spot a battery before it fails.

UPS BYPASSES

There are two primary types of UPS bypasses ; the Static Bypass and the Maintenance Bypass:

STATIC BYPASS

A static bypass is fitted to almost all On-line UPS; it forms a second line of defence. Should the inverter fail, the static bypass ensures the load drops automatically onto the mains input feed.

With an On-line UPS, if an inverter fails, it will, in all probability, occur whilst mains power is present.

A static bypass is in almost all cases part of the UPS internal circuitry and may be invoked manually using an external switch. In larger UPS, it will probably synchronise the UPS output with the mains cycle before switching, so may take a few seconds to engage.

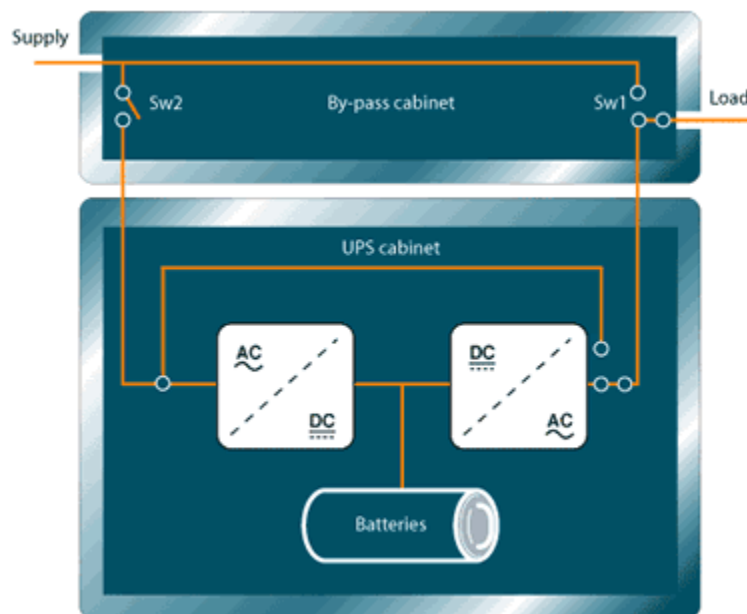

MAINTENANCE BYPASS

Known more descriptively as a wraparound bypass, this is fitted externally to the UPS and enables the UPS to be isolated for maintenance or repair without interrupting power to the load. On larger UPS the internal static bypass should be engaged before throwing the maintenance bypass. Some bypasses have interlocks to ensure this correct operation.

After setting the UPS into bypass mode (to synchronise with the mains supply), Sw1 is operated to provide raw mains to the load. Sw2 may be opened to allow safe working on the UPS or may be left closed if the engineer wishes to make tests with the power on.

BUSINESS CONTINUITY PLANNING

STANDBY POWER TO KEEP YOUR BUSINESS RUNNING

Forward thinking businesses understand the need for Business Continuity Planning. They appreciate how such a plan, if properly resourced and practised, will ensure the commercial 'life blood' of their business throughout a disaster.

YOUR BUSINESS CHALLENGE

Imagine how a sudden and unexpected power outage at your business premises, or even to certain locations within those premises, could impact your business's performance, reputation and security ... including the integrity of data held on your systems.

A loss of power for hours, minutes or even a few seconds could create havoc for your IT servers, computer networks, telephone and security systems, manufacturing processes or other ancillary services.

And it's not just a total power outage, a power surge (a spike) or a power dip (a brownout) can have the same devastating effect on IT systems and other sophisticated electronics.

Of course the biggest cost is the impact this may have on your customers. Without telephones, computers and the customer and product data they hold, your customer service levels will nose dive. The commercial impact could be enormous.

With this in mind it's easy to see why Standby Power is a proactive and cost effective investment.

Peace-of-mind

By installing an Uninterruptible Power Supply (UPS) you can be confident that your business will continue to function throughout any type of power disruption, from long term power outage to small scale degradation.

We provide a complete UPS solution from site surveys, installation, preventative maintenance, regular health checks and remote monitoring of your back-up power devices. UPS Systems is independent of any manufacturer and we will work with you to select the most appropriate solutions available in the marketplace, ensuring that your Standby Power mirrors your business needs.

POSSIBLE POWER PROBLEMS

Disruption to electrical power quality takes many forms, from complete outage to power surges and spikes, brownouts, switching transients or harmonic distortions. Your critical business systems may react in varying ways to these different power conditions, you can learn more here.

If your mains power goes off, you'll need a UPS to provide stored power for short runtimes. A UPS will maintain power by switching instantaneously to batteries in the event of a mains failure or even just a dip in power (a brownout).

Some UPS are designed to allow a controlled shut-down of your IT servers whilst others may be used with a standby generator to allow the whole building to continue running. Designing a Standby Power solution for a business requires an understanding of both the power protection and generation. Other parts of this website provide information on the range of UPS Technologies available, Generator types and those situations where Fuel Cells have now become a realistic alternative.

We maintain what is arguably the UK's largest database of Standby Power products from all major suppliers. Combining our expertise in Standby Power with this powerful database, we are uniquely able to select the solution that meets your very specific requirements. Should you require assistance, please call us.

THE BUSINESS DRIVERS

Computer disasters often lead to business failures – 90% of all companies that experience a computer ‘disaster’ and have no survival plan, go out of business within 18 months. (Source: Price Waterhouse).

Increased availability of computer systems - 28% of all computer system breakdowns are caused by power failures.

Prevents loss of reputation - Insurance cannot provide relief from the loss of goodwill, market share and damage to a company’s reputation following a computer ‘disaster’.

Improved profitability - More than 33% of organisations that experience a computer ‘disaster’ lose between £7,500 and £250,000. 20% lose between £250,000 and £750,000. 15% of companies lose over £750,000.

Improved employee productivity - Organisations suffer an average of 6 computer failures a year. On at least one occasion it takes 4 hours to get the system up and running again, leaving employees stranded.

Eliminates recovery time - Over 33% of companies that suffer a computer ‘disaster’ take more than a day to recover from the disruption. 10% take more than a week.

Prevents long recovery cycles - Insurance claims are not normally settled until long after the ‘disaster’ has occurred.

Eliminates re-inputting of data - The re-inputting of lost data can take days, weeks, or even months. Sometimes data is lost forever.

Eliminates need for system reconfiguration - It can take up to 48 hours to reconfigure a multi-terminal or network system following a power failure.

REMO – REMOTE MONITORING FOR STANDBY POWER SYSTEMS

REMO®

Remote Monitoring Service from UPS Systems Available on most brands of UPS, on all Generators and now fuel cells, the UPS Systems remote monitoring service (REMO®) provides constant monitoring while the unit is in operation by sending a text or email to multiple addresses, the instance a problem occurs.



Chapter 7:
Implementation
& Budget Plan

STEPS FOR IMPLEMENTATION

PROCEDURE

1. Shine halogen light source on cells of the solar panel.
2. Read voltage measured across the leads of the solar panel.
3. Expect measurement to be greater than zero volts.

To test functionality of photoresistors:-

1. Shine halogen light source on photoresistor frame.
2. Read that a voltage is measured and that configuration provides enough difference between individual photoresistors.
3. Expect measurement to be greater than zero volts.
4. Cover three of the photoresistors and shine light source on only one photoresistor.
5. Expect all covered photoresistors measure zero volts and the uncovered measures a values greater than zero volts.

To test functionality of Arduino/photoresistor interconnects:

(Note: At this point, the Arduino code will be in test phase, containing a section included which will print out the values of the voltage measured from each photoresistor and which photoresistor the light source is most likely directed to.)

1. Attach photoresistor output wires to appropriate input pins on Arduino.
2. Shine light on photoresistor configuration, pointing closer to one photoresistor specifically. Mark down which photoresistor is chosen.
3. Expect the Arduino to measure voltage from each photoresistor and logic determines the light source comes from the direction of the previously chosen photoresistor.

To test functionality of entire device (photoresistors/Arduino/Stepper Motors):

(Assuming all wires are appropriately attached)

4. Shine light on photoresistor cone, pointing closer to one photoresistor specifically. Mark down which photoresistor is chosen.
5. Expect the Arduino to measure voltage from every photoresistor, the direction from which the light is coming from based on photoresistor placement is determined by logic, and the stepper motors orients the solar panel to point in the direction of the light source.

To test the functionality of the motion detection sensor:

1-connects the infrared sensor to the power source and check if the input led indicates that the infrared sensor is working.

2- if the led worked then this indicates that the infrared sensor has an output voltage = 12 volt

3- we used a voltage regulator to convert the voltage in to a maximum voltage of 5 instead of 12 .

Final Budget

The following table lays out the prototype financial costs.

Table 1: Final Budget

Part	Description	Qty	Rate	Subtotal	Link
Arduino mega 2560	- microcontroller board based on the ATmega2560 along with its cable	1	210	210	
Servo motor	- Metal Gear High Torque Servo Motor (15Kg)	2	145	290	http://store.fut-electronics.com/FUT-019.html
Solar Panel	- Solar panel (13.5 V / 5W) with solar charger	1 5 W	430	430	Cell Type: Multi-crystalline

Relay board	- 8 channel relay switch board	1	65	65	
Re-chargeable battery	- Lead battery (12V/4A)	1	95	95	
Adaptor	- DC adaptor (1A) used to power up arduino board	1	23.5	23.5	
Motion detector	- IR switch sensor (proximity)	1	70	70	http://store.fut-electronics.com/ELB1-DC36.html
RTC module	- Real time clock module	1	58	58	http://store.fut-electronics.com/SEN12671P.html
Power supply	-	1	100	100	
Artelon material	- Material used for mechanical design	10 Kg	18.5	185	

Arandid tube	- Adhesive		10	10	
LED	- LED diode	10	0.5	5	http://store.fut-electronics.com/D1LKIT.html
jumpers	- Male-male jumper wires	90	0.75	67.5	
	- Female-female	20	0.75	15	
Crocodile wire	- Crocodile wires bundle	1	7	7	
Extensions	- Servo Motor	2	9	18	
Resistors	- 100 Ohm,1k	0.10	16	25	
	Ohm, 10k	0.05	5		
	Ohm				
Nails	-	12	2	25	
Mechanical Design	- Gears & Cogwheels	5	280	1350	
TOTAL					2150



Chapter 8:
Conclusion &
Result

Conclusion & Result

In conclusion, this document addresses the major design decisions associated with constructing the sun tracking solar panel in order to control the auto intensity of a street light system. The high-level architecture of the design and an in-depth explanation of each individual component of the design, such as the software, hardware, integrated circuits, control system and mechanical components, were discussed. This document also included the system final test plan & budget. By reading this document, You will understand that the Designed prototype is a low cost arduino based system which automatically tracks the sun and control the auto intensity of the street lights.

The principle used is very easy and simple to implement. Hardware required for the design is not very costly and easily available in the market. It tracks the sun in such a way that only normal rays are incident on the Photodiode. therefore the output power will be maximum Hence the stored energy in the battery that will be used to light the leds (street lights) will be larger .



Appendix A

Code of Implementation

```
#include <TimerOne.h> // used for IR timer interrupt
```

```
#include <DS1307.h> // for rtc
```

```
#include <Wire.h> // for rtc wiring using i2c
```

```
#include <LiquidCrystal.h> // lcd
```

```
#include <Servo.h> // controlling motors
```

```
// LCD connections
```

```
// RS at 22
```

```
// E at 24
```

```
// D4 D5 D6 D7
```

```
// 26 28 30 32
```

```
// VDD +5V
```

```
// VSS GND
```

```
// A +5V
```

```
// K GND
```

```
// V0 mid of potentiometer
```

```
// potentiometer +5V GND
```

```
//create lcd object
```

```
LiquidCrystallcd(22, 24, 26, 28, 30, 32);
```



```
// +5V GND (red and black)

// SCL SDA

// 21 20

DS1307 clock;

// LDR threeshold

constintldrTH = A15;

int brightness; //led brightness

int intensity; //sun intensity

// Leds of IR

constintirLEDs[3] = {10, 9, 8};

// battery level pins

constintlevelPin = A7;

// battery level max and min

const float batteryMax = 12.9; // volts

const float batteryMin = 10.5; // volts

//constintledsNum = 8;
```

```
//constintlevelLeds[] = {2, 3, 4, 5, 6, 7, 8, 9};
```

```
// no of dividing resistors
```

```
constintdivRes = 3;
```

```
volatileint counter = 0;
```

```
volatileintlastCounter = 0;
```

```
// horizontal and vertical serovs
```

```
Servo horizontal; // horizontal servo
```

```
intservoh = 90; // stand horizontal servo
```

```
Servo vertical; // vertical servo
```

```
intservov = 90; // stand vertical servo
```

```
// LDR pin connections
```

```
// name = analogpin;
```

```
intldr1t = A0; //LDR top left
```

```
intldr1r = A1; //LDR top right
```

```
intldr2l = A2; //LDR down left
```

```
intldr2r = A3 ; //ldr down right
```

```
constintbatteryChargingPin = 41;
```

```

constintswitchPin = 43; //default is power supply

// use to set clock from program

voidsetClock(int year, intmon, int day, int hour, intminu, int sec, intwday =
SAT)
{
    // set date
    clock.fillByYMD(year, mon, day); //y,m,d
    // set time
    clock.fillByHMS(hour, minu, sec); //h,m,s
    // set day
    clock.fillDayOfWeek(wday);//day

    // ok set the given time
    clock.setTime();//write time to the RTC chip
}

// set clock from our program on a pc or a laptop from serial
voidsetClockFromSerial()
{
    // wait until clock is written

```

```
while (!Serial.available());

// buffer
char clk[8];

// read from serial into buffer
Serial.readBytesUntil('\0', clk, 8);

// create a new string object from char[]
String c(clk);

// get values from string
int hour = c.substring(0, 2).toInt();
int minu = c.substring(3, 5).toInt();
int sec = c.substring(6).toInt();

// just print it to serial again
// Serial.print("Now clock: ");
// Serial.print(hour);
// Serial.print(":");
// Serial.print(minu);
// Serial.print(":");
```

```
// Serial.println(sec);

// set the clock with any date and the time we got
// from the serial
setClock(2014, 10, 10, hour, minu, sec);
}

// get the current time from rtc as a string
String getCurrentTime()
{
clock.getTime();

String s="";

s += clock.hour;

s += ":";

s += clock.minute;

s += ":";

s += clock.second;

return s;
}
```

```
// reset car counter/timer
void resetCounter()
{
  for(int i=0; i<3; i++)
    analogWrite(irLEDs[i], 0);

  //Timer1.stop();
}

inline void startBatteryCharging()
{
  if(readLevel() < batteryMax)
  {
    digitalWrite(batteryChargingPin, LOW);
  }
}

inline void stopBatteryCharging()
{
```

```
digitalWrite(batteryChargingPin, HIGH);  
}
```

```
inline void switchToBattery()  
{  
digitalWrite(switchPin, HIGH);  
}
```

```
inline void switchToPowerSupply()  
{  
digitalWrite(switchPin, LOW);  
}
```

```
// interrupt service routine  
// which is called when the ir sensor value changed  
void onCarPass()  
{  
    // initialize timer1, and set a 6 * 1/2 second period  
    Timer1.initialize(10 * 500000);  
    //period is in microseconds  
    Timer1.attachInterrupt(resetCounter);
```

```
// NOTE:  
  
// set the timer output on pin 9  
  
// DO NOT USE THIS PIN !!  
  
// 50% duty cycle  
  
//Timer1.pwm(9, 512);  
  
  
// turn on leds with battery level  
for(int i=0; i<3; i++)  
analogWrite(irLEDs[i], brightness);  
  
  
//Timer1.start();  
}  
  
void initialPos()  
{  
if (servov < 90){  
servov = ++ servov;  
delay(20);  
}  
else if (servov > 90){  
servov = -- servov;
```



```
delay(20);  
}  
else{  
}  
if (servoh < 90){  
servoh = ++ servoh;  
delay(20);  
}  
else if (servoh > 90){  
servoh = -- servoh;  
delay(20);  
}  
else{  
}  
vertical.write(servov);  
horizontal.write(servoh);  
}
```

```
voidPos(int x){  
if (servov < x && servov != 0){  
servov = ++ servov;
```

```
delay(20);  
}  
else if (servov > x && servov != 180){  
servov = -- servov;  
delay(20);  
}  
else{  
}  
if (servoh < x && servoh != 0){  
servoh = ++ servoh;  
delay(20);  
}  
else if (servoh > x && servoh != 180){  
servoh = -- servoh;  
delay(20);  
}  
else{  
}  
vertical.write(servov);  
horizontal.write(servoh);  
}
```

```

// read the 4 directions LDRs and move the servos
// according to the LDR values
void read4LDRsandMoveMotors()
{
  intlt = analogRead(ldr1t); // top left
  intrt = analogRead(ldr1r); // top right
  intld = analogRead(ldr2l); // down left
  intrd = analogRead(ldr2r); // down right

  intdtime = analogRead(4)/20; // read potentiometers
  inttol = analogRead(5)/4;

  intavt = (lt + rt) / 2; // average value top
  intavd = (ld + rd) / 2; // average value down
  intavl = (lt + ld) / 2; // average value left
  intavr = (rt + rd) / 2; // average value right

  intdvert = avt - avd; // check the diffirence of up and down
  intdhoriz = avl - avr; // check the diffirenceog left and right

```

```
if (-1*tol>dvert || dvert>tol) // check if the diffirence is in the tolerance else  
change vertical angle
```

```
{  
if (avt>avd)  
{  
servov = --servov;  
delay(20);  
if (servov> 180)  
{  
servov = 180;  
}  
}  
else if (avt<avd)  
{  
servov= ++servov;  
delay(20);  
if (servov< 0)  
{  
servov = 0;  
}  
}  
}
```

```
vertical.write(servov);  
  
}  
  
if (-1*tol>dhoriz || dhoriz>tol) // check if the diffirence is in the tolerance  
else change horizontal angle  
  
{  
if (avl>avr)  
{  
servoh = --servoh;  
delay(20);  
if (servoh< 0)  
{  
servoh = 0;  
}  
}  
else if (avl<avr)  
{  
servoh = ++servoh;  
delay(20);  
if (servoh> 180)  
{
```

```
servoh = 180;
    }
}
else if (avl = avr)
{
    // nothing
}
horizontal.write(servoh);
}
delay(dtime);
}

// read the value of battey and return
// the real value instead of a digital one
floatreadLevel()
{
int value = analogRead(levelPin);
return (map(value, 0, 1023, 0, 500) / 100.0) * divRes; // *divRes = 1/divRes
}

// output the current time of rtc to the first row of lcd
```

```
void outputTime()
{
  lcd.setCursor(0, 0);
  lcd.print("Time: ");
  lcd.print(getCurrentTime());
}
```

// output the level of battery to the second row of lcd

```
void outputBatteryLevel()
{
  // int level, ledsOn;
  // level = readLevel();
  // //Serial.println(level);
  // ledsOn = (int) (((float) level / batteryMax) * ledsNum);
  //
  // //Serial.println(ledsOn);
  // //delay(300);
  // for(int i = 0; i < ledsNum; i++)
  //   digitalWrite(levelLeds[i], HIGH);
  //
  // for(int i = 0; i < ledsOn; i++)
```

```

    // digitalWrite(levelLeds[i], LOW);

    //Serial.println(readLevel());

    lcd.setCursor(0, 1);

    lcd.print("Battrey: ");

    lcd.print((readLevel() / batteryMax) * 10000 / 100.0);

    lcd.print("%");
}

// get the time from rtc

// and move the servos according to a certain time periods

voidgetTimeAndMoveMotor()
{
    getCurrentTime();

    // from 1 to 6 pm, set our recommended position
    if(clock.hour>=07 &&clock.hour<= 9)
    {
        Pos(180);
    }

    // from 7pm to 5am deactivate the servos
    else if(clock.hour> 9 || clock.hour<= 13)
    {

```



```
initialPos();  
  
}  
  
if(clock.hour>13 &&clock.hour<= 17)  
{  
Pos(0);  
}  
  
//else {  
  
// read4LDRsandMoveMotors();  
  
//}  
}  
  
void setup() {  
  
// begin serial communication, lcd connections and rtc clock  
clock.begin();  
Serial.begin(9600);  
lcd.begin(16, 2);  
  
// IR interrupt  
attachInterrupt(4, onCarPass, LOW); // int4 on pin 19  
  
// servo connections
```

```
// name.attach(pin);  
horizontal.attach(3);  
vertical.attach(4);  
  
//setClockFromSerial();  
setClock(1, 1, 1, 13, 1, 1);  
}  
  
void loop() {  
  //lcd.clear();  
  
  //if(millis() % 10000 == 0)  
  //{  
    outputTime();  
    outputBatteryLevel();  
  //}  
  
  intensity = analogRead(ldrTH);  
  intensity=1023-intensity;  
  brightness = map(intensity, 0, 1023, 0, 255);
```

```
// check for the threshold of light

// if the light is less than or equal to 20% = 204.6 then

// it should work from rtc

// else it should work from the 4 directions LDRs

if(analogRead(ldrTH) <= 204.6)

{

getTimeAndMoveMotor();

}

if(clock.hour >= 17 || clock.hour <= 7)

{

stopBatteryCharging();

}

else

{

startBatteryCharging();

}

}

else

{

if(!(clock.hour >= 17 || clock.hour <= 7))
```

```
{  
startBatteryCharging();  
}  
  
read4LDRsandMoveMotors();  
}  
}
```